

Interview: Scott Wade

Research: Freeform Microlens Arrays

Technologies: Smart Buildings DC Grids

Applications: Office Lighting Controls

**FUTURE**  
Lighting Solutions  
www.FutureLightingSolutions.com  
**2019 LIGHTFAIR International**  
May 19 – 23, 2019  
Visit us at our stand!  
We look forward to seeing you.  
Booth #1349



## Lighting that captivates shoppers—and moves merchandise.

Lighting is essential in creating a unique shopping experience that helps retailers attract repeat business. For any effect your retail customers demand, choose Lumileds High Impact Retail Lighting Solutions for your luminaire designs.

This complete portfolio of LEDs for High Impact Retail helps you distinguish each retailer's brand through differentiated, consistent experiences. The CrispColor and CrispWhite Technologies featured in the LUXEON Stylist Series can be precisely tuned for signature colors and showcasing merchandise. And you get best-in-class performance and efficiency with every LED, CoB or ready-to-deploy Matrix Platform configuration.

**To find out more, visit [lumileds.com/high-impact-retail](https://lumileds.com/high-impact-retail) or contact your Lumileds Sales Representative.**



LUMILEDS ILLUMINATION LEDs

LUXEON HIGH POWER LEDs • LUXEON MID POWER LEDs • LUXEON CoB LEDs • LUXEON COLOR LEDs • LUXEON IR • MATRIX PLATFORM

# Clever solutions for a connected world

Fulham's innovative drivers bring tomorrow's technology to today's luminaires.

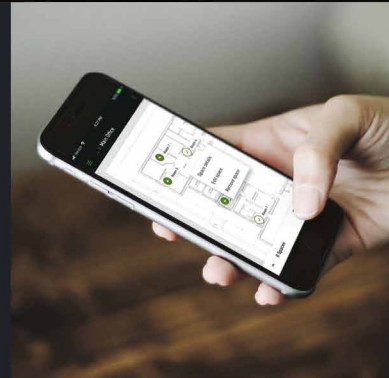

**FULHAM**  
ELITECONTROL

### EliteControl Connected Driver: The Simple Power of Bluetooth

A dimmable constant current driver with the unique ability to add Bluetooth mesh connectivity with a simple plug-and-play antenna. Compatible with Bluetooth sensors, wall switches, and other devices, the connected driver serves as the core component for powerful, easy-to-expand lighting systems.

**FULHAM**  
HOTSPOT LED

### HotSpot Plus: The All-in-One Emergency Driver

The first fully integrated programmable LED driver, emergency LED driver, and replaceable backup battery. A revolutionary design that reduces costs, simplifies installation, and brings emergency capability to smaller luminaires. Ultra thin form factor now available.



**T2C1UNV150P-40L**  
40W Connected Driver

**ESLI01HB01**  
Bluetooth Antenna  
(Optional)



**FHSAC1-UNV-70S**  
70W All-in-One Solution



# Connected Miniaturized Lighting

In this issue of the LED professional Review (LpR) we want to catch up on the current topics in the lighting world again and also touch on future development and some of the main trends.

One topic that affects lighting technologies is progressing miniaturization. The control electronics, in particular, are still too heavy in relation to the LEDs and determine the form factors. There are two main directions concerning this topic that are dealt with:

On the one hand, Micro-LEDs are becoming a rapidly growing segment and optimized optics are required for this purpose. On the other hand, there is the approach of "centralizing" the electronics and supplying the energy via a DC grid. The topics in the automotive sector are also related and offer interesting solutions for miniaturization.

The second major area, in addition to miniaturization, is networking and, in a broader sense, Smart/AI controlled systems. This edition also concerns itself with EnOcean technology, a method of transmitting data without energy storage and the DALI standard, an interface that is developed, promoted and supported worldwide by the DiiA organization.

The DiiA (Digital Illumination Interface Alliance) will also host the first DALI Summit in Bregenz on September 25<sup>th</sup>, 2019, which will take place parallel to LpS 2019 and TiL 2019.

We're sure you'll enjoy this edition and look forward to your feedback!

Yours Sincerely,



Siegfried Luger  
Publisher, LED professional

Almost too beautiful just  
for the road – lighting  
design with PLEXIGLAS®.

What does a leading specialty chemicals group have to do with car design? For over 60 years, Evonik, with its PLEXIGLAS® molding compounds, has been a driving force behind the auto industry. Why? Because the multifaceted ways in which PLEXIGLAS® can be formed open up virtually endless possibilities for design. One shining example is crystal-clear or colored PLEXIGLAS® whose top light-guiding properties and color stability make for innovative automotive lighting systems. For more inspirational PLEXIGLAS® products, go to [www.plexiglas-polymers.com](http://www.plexiglas-polymers.com).

PLEXIGLAS® 



 **EVONIK**  
POWER TO CREATE

COMMENTARY

08 What the Heck is Future-Proof?  
by Arno Grabher-Meyer, LED professional

TECH-TALKS BREGENZ

34 Dr. Scott Wade, DiiA  
compiled by Dr. Guenther Sejkora, LED professional

RESEARCH

42 Semi-Empirical Characterization of Freeform Microlens Arrays  
by Oscar Fernández et al., CSEM & ANSYS

50 Thermal and Optical Challenges for SSL in Automotive Applications  
by Umut Zeynep Uras et al., Ozyegin University & FARBA Corp.

TECHNOLOGIES

60 LED Lighting Systems in Smart Buildings with DC Microgrids  
by Carsten Moellers, Abalights

APPLICATIONS

66 Technologies for Shared Office Space  
by Matthias Kassner, EnOcean GmbH

REGULARS

04 EDITORIAL  
08 COMMENTARY  
10 COMPONENT NEWS  
20 APPLICATION NEWS  
25 RESEARCH NEWS  
28 ORGANIZATION NEWS  
32 REGULATION NEWS

74 ABOUT | IMPRINT

HIGHLIGHTS

42 Semi-Empirical Characterization of Freeform Microlens Arrays  
by Oscar Fernández et al., CSEM & ANSYS

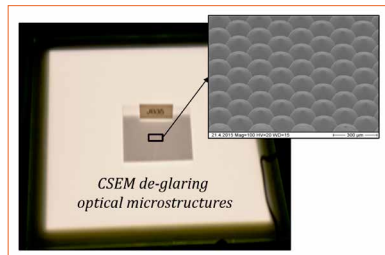

50 Thermal and Optical Challenges for SSL in Automotive Applications  
by Umut Zeynep Uras et al., Ozyegin University & FARBA Corp.

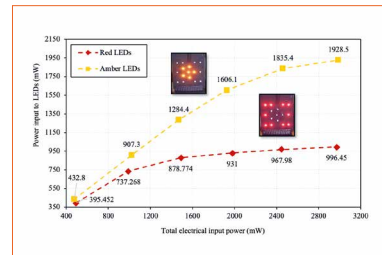

ADVERTISING INDEX

FUTURE LIGHTING SOLUTIONS	1	M.A.L. EFFEKT TECHNIK	17	TIL	55
LUMILEDS	2	CREE	21	HKTDC HK INT. LIGHTING FAIR (SPRING)	59
FULHAM	3	FLS-NICHIA	27	LIGHT FAIR INTERNATIONAL	65
EVONIK	5	FLS-SIGNIFY	29	LED EXPO THAILAND	69
FUTURE LIGHTING SOLUTIONS	7	FLS-LUMILEDS	31	CREE	72
LUMINUS DEVICES	9	TÜV SÜD	33	BRIDGELUX	72
INPOTRON	11	DIIA/DALI	41	GUANGZHOU INT. LIGHTING EXHIBITION	73
M.A.L. EFFEKT TECHNIK	12	INSTRUMENT SYSTEMS	45	LPR	75
GL OPTIC	17	LPS	49	WÜRTH	76

# We Accelerate Time to Revenue by Providing

- The Most Comprehensive System-Level Product Portfolio
- Solid-State Lighting Expertise
- Design Support Services
- Global Supply Chain and Business Solutions

**2019 LIGHTFAIR International**  
May 19-23, 2019  
Philadelphia, PA USA  
Pennsylvania Convention Center  
Booth #1349



[www.FutureLightingSolutions.com](http://www.FutureLightingSolutions.com)

Making LED Lighting Solutions Simple™

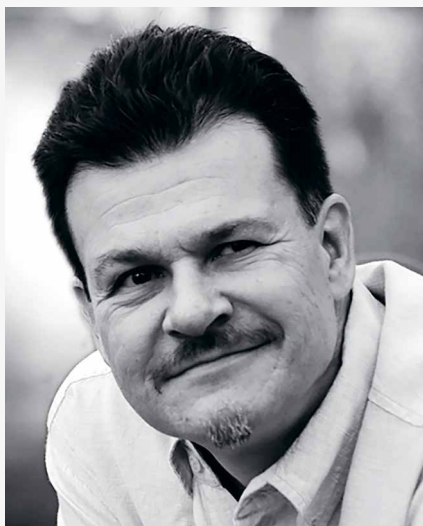

### Arno Grabher-Meyer

Arno originally studied biology at the University of Innsbruck. He was involved in several scientific documentation projects for the Alpenzoo (Alpine Zoo) and a documentary film for the BBC with Sir David Attenborough. He worked as a freelance photographer for the Inatura (Museum for Nature, Humans and Technology) in Dornbirn.

He earned his engineering degree through continued education and in 2005 went to work for Luger Research. Here Arno worked on several LED lighting research projects in conjunction with the Austrian Competence Center Light.

His job as Chief Editor started in 2006 when Luger Research initiated LED professional. Part of this multi-faceted job is being responsible for the editorial content of the magazine and online news.

## WHAT THE HECK IS FUTURE-PROOF?

The first time the question about future proofing LED systems came up seriously, was at LightFair 2018 when Siegfried Luger interviewed Patrick Durand. Since then, it has been the buzzword throughout the industry. Discussions concerning future proofing are often limited to wireless communications, IoT and some type of AI. But isn't there more?

The term future proof usually implies that any necessary measure from replacing in part or as a whole to upgrading or adding new features should be possible with minimum (financial) effort. But future proofness may concern different properties of the product or system depending on the stakeholder. Users, installers and owners may all have different views. The requirements are also different for different applications. So, let's walk through some of the different aspects.

Today's discussion about future-proofness, in fact, targets only a small fraction of all indoor installations because they often don't take advantage of LEDs controllability. This segment is very important for the industry as it is the high-priced part of their business that, if triggered correctly, promises growth and has the potential to free the industry from the current dilemma of not being as profitable as required. But how about users, installers and owners?

In many applications, the clients either don't recognize a (monetary) advantage or value. Additionally, while the industry frantically tries to convince the consumer of their smart concepts, there is still a lot of skepticism - justified or not. While people unquestioningly use Facebook and other social media as well as the Google and Siri systems that can compromise privacy and data safety, questions arise when it comes to smart lighting & IoT. Is it necessary to provide all my data to a cloud system? Isn't it sufficient to process just my local data in-house? Who else can access to my data and how will it be used? Is my data safe? Is my system safe or can it be hacked? Can my sensors be used for surveillance in the style of "Big Brother"? How is future-proofness to be seen in this light?

In outdoor applications, especially public (street) lighting, the situation seems to be different. Remote monitoring of the lighting equipment is not really new. The "customer" is already used to it. For them, some new

features are added and the technology behind the scene is changed. Upgrading to a smarter system with a change to LEDs seems to be a no-brainer. While the question of whether the potential of these new systems is fully utilized by the operator arises, it is important to ask: Which attributes make such systems future-proof?

At the other end of the scale, the availability of a replacement in case of a failure may be considered future proof. Solutions like using Zhaga compliant components seem to be the simple answer. Unfortunately, this isn't so! What happens when an LED module in an environment has to be replaced after 10,000 hours because it fails? The replacement might be more efficient, or not exactly hit the color point of the original LEDs, etc. But if we assume we are lucky enough to find an identical module or another acceptable solution with almost identical dimming curves, is the problem solved? No. In the beginning it works well, but what happens after a year or two? The degradation of the new module is certainly going to be different from the further degradation of the older module(s). Is this truly future-proof?

But it could be even worse. At LpS 2018, DI Markus Heckmann from Osram showed in his lecture "Influence of Converter Topology on the System Interactions" that the characteristics of LEDs from generation to generation may change in a way that some driver topologies that worked perfectly with the original LEDs may not be able to drive the updates correctly. This isn't future-proof, is it?

Finally, another often ignored aspect: LEDs are considered non-toxic, but LEDs, in fact, contain precious materials that are crucial for many products. Unfortunately, LEDs and LED products are, in many cases, landfilled. Especially as these materials are becoming scarce, this isn't sustainable and rarely environmentally friendly, and hence also cannot be described as future-proof.

A coordinated recycling program for LEDs as proposed in LightingEurope's Circular Economy Program is therefore urgently needed. I believe we should consider all aspects and think about future-proofness in a bigger context! ■

A.G-M.



# Luminus PerfectWhite™

Spectrally tuned to deliver the visual effect of halogen by filling the cyan gap present in most white LEDs for the beautiful color you expect.

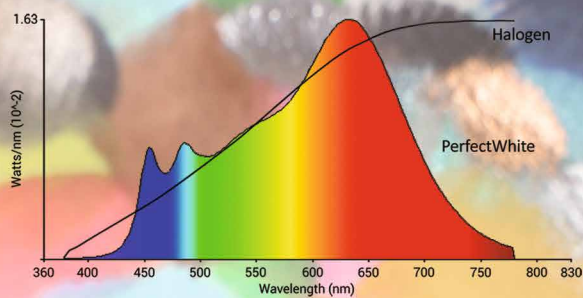

PerfectWhite™ spectrally tuned sources are essential components of human centric lighting and are ideal sources for retail and museum applications.

 **LUMINUS**  
WWW.LUMINUS.COM/PW



## Lumileds Unveils Luxeon Flash 9X with Spectral Pure Technology

Lumileds reasserted its market leading position in camera flash LEDs while at Mobile World Congress by introducing the Luxeon Flash 9X with Spectral Pure Technology LED that produces photos with the finest color quality. Noted for its small form factor (1.4x1.4 mm chip scale package), this robust LED is ideally suited to produce photos with vivid colors including the most realistic skin tones captured on any smart phone.

"The improved picture quality with Spectral Pure Technology is stunning when compared side-by-side with photos captured at 80 CRI, the former industry standard. Pictures taken with LEDs supported by Spectral Pure Technology have richer colors and facial tones appear more attractive than before," said Thierry De Smet, Director of Product Marketing at Lumileds.



**Lumileds' Spectral Pure Technology produces photos with exceptional color quality - especially realistic skin tones**

Key to this exceptional color quality is the spectral optimization of the camera flash, which matches the camera response curve and is characterized by its Camera Color Index (CCI), a more effective metric Lumileds is introducing to replace Color Rendering Index, CRI, for camera applications. "CRI really only applies when viewing objects directly with the human eye, but a camera captures colors differently, and the flash should be designed to counter this difference," said De Smet.

The Luxeon Flash 9X with Spectral Pure Technology is a high power LED that features industry leading flux of 240 lm at 1 A drive current and 25°C, and is hot flux stable at higher currents. The flash is produced at 4500 K color temperature with excellent color stability of ±250 K. Lumileds provides the highest reliability devices with the industry's first 1:1 LED traceability. ■

## New Mid-Power UV-LED With Quartz Window from Vishay

Vishay Intertechnology, Inc. introduced a ceramic mid power ultraviolet (UVC) emitting diode for sterilization, sanitation, and purification applications. Featuring a quartz window, the Vishay Semiconductors VLMU35CM00-280-120 delivers an extremely long lifetime in a compact 3.5x3.5x1.2 mm surface-mount package.

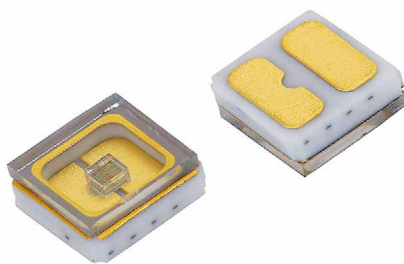

**Vishay's new UV LED ceramic device features a radiant power up to 18 mW and has a quartz window to deliver an extremely long lifetime**

### Features:

- Ceramic SMT package with quartz window
- Dimension (LxWxH) in mm: 3.5x3.5x1.2
- Forward current: up to 150 mA
- Radiant power (typ.): 12 mW at 100 mA
- Leads / terminations finish: gold plated (Au)
- Reflow soldering method
- MSL 3 according to J-STD-020
- Material categorization: for definitions of compliance please see [www.vishay.com/doc?99912](http://www.vishay.com/doc?99912)

### Applications:

- Sterilization
- Medical application
- Sensing of gases, germs, DNA, ...

Designed to replace mercury UVC lamps, the device released today offers an emission angle of ± 60° and radiant power to 18 mW at 100 mA without the need for an external lens. Built on AlGaIn technology, the VLMU35CM00-280-120 features forward current up to 150 mA, forward voltage down to 4 V, and a wavelength range of 270-290 nm.

The emitter diode's specifications make it ideal for water and air purification, physical surface sterilization, medical disinfection, and portable sanitizers. RoHS-compliant, halogen-free, and Vishay Green, the VLMU35CM00-280-120 is compatible with reflow soldering processes and features a Moisture Sensitivity Level of 3 in accordance with J-STD-020. ■

## Cree Announces Best-in-Class Horticulture Efficiency with New Red XLamp LEDs

Cree, Inc. announces the next-generation XLamp® XP-E2 Photo Red (660 nm) and Far Red (730 nm) LEDs, delivering breakthrough performance for horticulture applications. The new Red XP-E2 LEDs provide a drop-in upgrade for the previous generation that outperforms competing LEDs by up to 68%. These higher-performance horticulture LEDs increase the efficiency of LED luminaires and shorten their payback periods, making it more affordable to grow food under optimized lighting.



**XP-E2 Photo Red and Far Red LEDs deliver up to 68 percent higher performance than competition in tomato farms**

"Lettuce and tomato farmers in the UK, the Netherlands and Belgium are choosing our Hyperion™ grow lights, powered by Cree's horticulture LEDs, as the primary light source for their large indoor, state-of-the-art growing facilities," said Jonathan Barton, Director of Grow Lighting at Plessey Semiconductors. "Our customers like that the Hyperion™ lights replace 1000 W sodium lights one-for-one with up to 40 percent energy savings that are enabled by Cree® LEDs. We are pleased that Cree is delivering this efficiency upgrade in a form that's easily integrated, so that we can quickly improve our product's performance."

The new XP-E2 LEDs are a drop-in upgrade for existing XP-based horticulture designs with the same mechanical and optical characteristics as the previous generations. With up to 57 percent improvement in Far Red and up to 21 percent improvement in Photo Red, this new generation of XP-E2 LEDs delivers industry-leading output levels and efficiency within their performance class.

"LEDs for specialty applications, including architectural lighting and horticulture, are a

core part of our product strategy," said Claude Demby, Cree LEDs Senior Vice President and General Manager. "Cree is first to enable full spectrum luminaires that employ Photo Red and Far Red LEDs to deliver 50% energy savings over sodium-based lighting systems. This upgrade to our horticulture LEDs demonstrates our commitment to delivering industry-leading high-power LED performance." ■

## Bridgelux Triples Vesta® Series Family of Tunable White Products

Bridgelux has announced a dramatic expansion of the Vesta® Series family of tunable white and dim-to-warm products to help customers meet the increasing demands for environment-specific, personalized lighting.



**Bridgelux's Vesta® Series family of tunable white and dim-to-warm has been extended with new CCT options and new LES sizes**

Last year, Bridgelux announced the new phosphor dispensed architecture for Vesta Tunable White chip-on-board (COB) LED array products delivering increased efficacy and lumens per dollar.

Bridgelux is bolstering its Vesta Tunable White phosphor dispensed parts with:

- New proprietary packaging technology that significantly improves near field color uniformity and enhances beam quality when used with secondary optics
- Expanded product portfolio to include 15, 18, 22 and 29 mm LES sizes that deliver up to 10,000 lumens, enabling the adoption of color tuning into more applications
- New color range options across all LES sizes, tunable between 2700 Kelvin (K) and 5000 K or between 2700 K and 6500 K

Light is at the heart of life. Dynamic, flexible, high quality of light enables personalized

environments, and increased contentment, productivity and well-being. The growing trend towards IoT and smart lighting sets the stage for increased interactivity with lighting. Bridgelux has the industry's largest portfolio of tunable white products, enabling lighting installations that can be optimized to meet the needs of specific environments, applications and inhabitants, a human centric lighting solution.

These new products complement the recently announced Vesta Series Edge, a 570 mm linear solution that delivers a uniform and vibrant edge-lit panel lighting experience with a CCT range of 2700 - 5000 K. Vesta Edge will improve office and commercial lighting where low-glare, dynamic white illumination is specified.

"Retail, office, education and healthcare markets are increasing their demand for lighting that can be tuned to the needs of their customers, employees, students and patients while adhering to various protocols and standards," said Aaron Merrill, Vice President of Marketing at Bridgelux. "We've expanded our portfolio to meet these evolving demands and we're growing our ability to support the evolution toward human centric lighting, the right light in the right place and at the right time." ■

Vesta Edge and the new Vesta Tunable White arrays in 9, 13 and 18 mm form factors are available for ordering since March, while the other form factors will be available for ordering shortly thereafter. ■

## Nichia Expands Its Optisolis™ Technology Into a CoB Series

Nichia Corporation is proud to expand its award winning Optisolis™ natural light source technology with a portfolio of COB packages. To further improve the overall quality of light as "AKARI", Nichia has developed Optisolis™. As Nichia continues to lead the industry with innovative products, Optisolis™ provides a natural light source with a spectrum that achieves the industry's closest match to that of the standard illuminant, including both the sun and incandescent. Optisolis™ is optimized for the general lighting market and is accomplished through Nichia's own blue chip and phosphor technology.

Professional Power

**InpOTRON™**

Schaltnetzteile  
Switch Mode Power Supplies

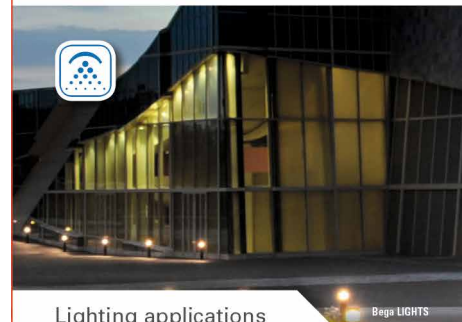

Lighting applications

### Switch Mode Power Supplies

- customized development
- efficiently
- smart



Customized Solutions  
Made in Germany



[www.inpotron.com](http://www.inpotron.com)

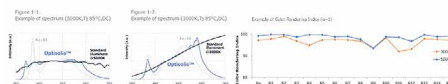

**Nichia expands its award winning Optisolis™ natural light source technology with a portfolio of COB packages raising the standard for color quality**

Nichia has launched the Optisolis™ technology in a CoB series that features high luminous flux and a narrow emission area. The CoB footprint is ideal for products that require high light density, including spot lights, down lights, track lights and more. The Optisolis™ CoB further raises the standard for color quality.

Manufacturers can utilize Optisolis™ and trust in a spectrum where all colors are reproduced to that seen under a standard light. Most importantly, since UV emission is essentially non-existent in the spectrum, the degradation of irradiated materials can be reduced dramatically compared to that of other light sources containing UV emission, including other market available LEDs.

- High Speed SMD Assembling 
- R&D Department 
- Light Laboratory 
- Customized & Unique Solutions 
- ISO Standards 
- After Sales Service 
- High Quality 



# Diversity *re*defined.

*ix*led modules - 1,500 new, innovative LED products

Order your sample now:  
[www.mal-effekt.de/sample](http://www.mal-effekt.de/sample)

**m.a.l.**<sup>®</sup>  
modern.art.of.light.



m.a.l. Effekt Technik GmbH | Wiesenweg 6 | 36179 Bebra  
Phone +49 (0) 6622 9133-0 | Mail [info@mal-effekt.de](mailto:info@mal-effekt.de)

Optisolis™ target applications include Museums, Art Galleries and Hospitals, where a natural light source is preferred to most accurately represent an object, but UV radiation and light sources can be detrimental. Additional applications could include color evaluation (e.g. painting, printing), commercial lighting (e.g. retail, etc.) or anywhere a natural light source is desired. ■

## Lumitronix Expands SmartArray Series with High Efficiency RGBW Version

With its new SmartArray Q4 RGBW module, Baden-Württemberg LED specialist Lumitronix presents an extension to its successful SmartArray family. The square LED module, which is ideally suited as a replacement for COB modules due to its compact dimensions of only 13.5x13x1.08 mm, is equipped with a red, a green, a blue and a neutral white LED of the E17A series from Nichia.

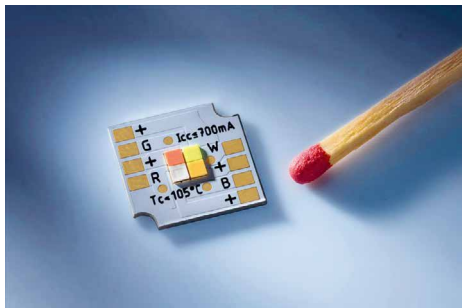

Lumitronix's new SmartArray Q4 RGBW is a compact solution for high quality CCT & color tunable lighting applications

### Features of the SmartArray RGBW module:

- High-quality LEDs from the Nichia E17 series
- Colored LEDs with innovative phosphorus conversion
- Replacement for COB modules
- Compact and flat design
- Easy installation
- Homogenous light due to Nichia-Binning (3 Step MacAdam)
- For ambient lighting, architectural lighting or lighting for films & television
- Made in Germany
- 3-year warranty

"The special aspect of the colored LEDs is the phosphorus conversion that Nichia has opted for in its manufacturing process," Christian Hoffmann, CEO of the Hechingen-based LED company, reports.

The basis in each case is a blue LED chip that emits the desired light color through a special phosphor layer. Since the chips used have the same electrical properties, the colored E17 LEDs are suitable for applications with a wide color spectrum. "The technology is particularly advantageous in terms of color stability, because both ageing and temperature dependence of the individual colors are much more consistent than that of RGBW modules with different semiconductors," Hoffmann continues.

In addition, the SmartArray Q4 RGBW has been tested with optics from the Gabriella series of the Finnish manufacturer Ledil, which can be fully recommended for use. Applications of the four-color LED module from Lumitronix include ambient lighting, architectural lighting and lighting for film and television. ■

## High-output Broadband LEDs Capable of Emitting Visible Light to Near-infrared Light

Ushio Opto Semiconductors has recently developed a broadband LED that produces the world's maximum output of 160 mW over a wide bandwidth between 400 and 1000 nm, which covers the range from visible light to near-infrared light. From the 1<sup>st</sup> of December, Ushio Opto Semiconductors, Inc. started shipping samples from its new "Spectro Series" lineup as part of the "epitex series" LED brand.

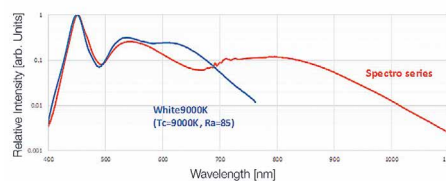

Spectral data (top) and Spectro Series product images (from left to right) SMBB flat type, SMBB lens type, TO-66 type, SMG type

Because the absorption characteristics of near-infrared light differ from one substance to another, they are widely used in the fields of foodstuffs, medicine, and so on, as a method of determining the kind and amount of a substance, such as sugar content or blood oxygen saturation level. In recent

years, there have arisen demands for smaller measuring devices, such as foodstuff sensors that are portable.

In addition, the light from the light source, which extends from the visible region to the near-infrared region where the wavelength is about 1000 nm, roughly matches the spectral sensitivity of the silicon photo detector that typically employs a CMOS device. It is therefore hoped that by combining the light source with a photo detector, it can also be used as a sorting unit that sorts materials, colors, and other properties of PET bottles, for example.

However, in the case of existing light sources, miniaturization and maintainability are issues for the following reasons:

In the case of conventional near-infrared LEDs, monochromatic light can be received from one device, and in order to measure different materials using a single device, it is necessary to install multiple devices, which makes miniaturization difficult to realize.

LEDs covering a wide range of wavelengths, including near-infrared, which are being used in recent years, produce a weak output. Consequently, adequate light output cannot be obtained, making measurement difficult to perform.

Halogen lamps that produce high output and emit light over a wide range of wavelengths are a large light source, which also cause various other parts in the vicinity of the lamp to be heated by the light. For this reason, it is necessary to install a heat-dissipating jig, which makes miniaturization difficult to achieve. Also, compared to an LED, halogen lamps have a short life, and must be replaced frequently.

In contrast to the above, Ushio Opto Semiconductors, Inc.'s strength lies in the development and manufacture of LEDs, particularly in the infrared area where much work has been carried out by our predecessor organization. By making optimum utilization of our technology and know-how, we have been able to realize an LED that has an output of 160 mW, the highest in the world. This type of LED uses a fluorescent material that features a continuous spectrum extending from visible light to near-infrared light.

It is hoped that this work will bring about the development of a device that enables an individual to measure the sugar content or fat content of foodstuffs, for example, and also increase the efficiency of sorting units that can sort the raw materials, colors and foreign matter in agricultural produce and plastic products.

"Spectro Series" products will be available in multiple forms, from various packages to "Chip on Board," at the request (output, light distribution, and size of the light source) of the customer. ■

## Forge Introduces Reliable, Adaptable LED Modules Including a Narrow Angle Optics

In recognition of the demand for high-performance reliable LED modules, that do exactly what luminaire manufacturers want, Forge has introduced a custom module to do exactly that. Forge has never been a one size fits all manufacturer, and with the release of this latest customizable module offering, the added value they bring to product development and manufacturing is evident.



**Forge's latest LED modules follow the company's philosophy to provide customizable solutions to luminaire manufacturers**

Every luminaire has different LOR, thermal and optical properties, and every luminaire manufacturer wants a USP. Forge has the technical expertise to ensure manufacturers get only the very best modules in their fittings. How? With the ability to lengthen and shorten heat sinks, choose connectors and wire lengths, pick heat sink colors, add logos, and even incorporate specific fixing and mounting methods. All whilst giving manufacturers the peace of mind that their module will perform thermally, optically and reliably to pre-determined L70 expectations, through in-house testing.

Forge has also recently developed a <math><10^\circ</math> optic to suit the module perfectly, fulfilling that demand for a tight crisp beam pattern to complement the medium and wide offering. With Forge's optic design and manufacturing capability, you can also create your own bespoke beam pattern and achieve specific light distribution. All of this is before you even consider your light CCT and CRI requirements - you really can put light where you want it! ■

## Optoga Introduces Fully Integrated DALI 230 VAC LED Module

A new revolutionary LED module has seen the light at Optoga! Instead of large and bulky drivers, luminaire manufacturers can now really make their products extra premium for their customers. With a new DALI LED technology innovation, the Swedish company Optoga AB has created a remarkable new technology with unique benefits: a lighting module with a standardized communication protocol, without limits.



**Instead of using large and bulky external drivers, Optoga's Clara AC DALI 230 VAC combines 230 V AC-LED technology with a DALI interface**

The Clara AC DALI 230VAC is packed with cutting edge technology. Even the smallest detail has been refined and improved, and the energy consumption is among the lowest in the industry. Luminaire manufacturers can directly integrate DALI without any change in fixture construction or design. At the same time, it provides an opportunity to reduce energy consumption by up to 80%!

### Tough lighting requirements:

Optoga is specialized in LED technology and supplies light modules and related technologies worldwide. Stefan Larsson, CEO, says. "For many years, we have developed and integrated intelligent

communication into our LED modules which our customers can deploy quickly and easily. When we started developing the DALI platform, we were also given the task of developing a better and energy-efficient lighting solution for a customer and this is the result"

The requirements were tough. The design and the new technology should not be hard to implement and simply be functional and invisible. But both our customer and we wanted a quality light engine with superior performance with an advanced communication capability beyond what is usual. The light source should also have the highest color render and light quality.

### LED light with many features:

The light should also be more functional, extremely energy-efficient and should not be more expensive than earlier conventional LED drivers. The fact that we made it so small that it could be integrated directly into the LED module was initially very challenging because we internally assumed that the costs would exceed the budget, and that the quality of the light would be worse. "There are still many that believe that 230VAC LED products are not safe, not to mention with DALI communication added. The development progressed quickly and our LED modules are able to provide high quality color rendering, color temperature and a comfortable ambience." Overall, the new lighting device is significantly more cost effective than previous solutions.

### Up to 80% lower energy consumption:

The LED light source includes electronics that improve quality and functionality while further reducing energy consumption. This required energy-efficient solutions. "The existing analogue technology used in previous solutions consumes approximately the same amount of energy. The difference is that the new one is significantly more controllable as we have complemented the lighting to achieve additional features and have improved the user experience".

Communication through DALI should make it easier for the end users by simplifying the use of different settings and adding application options. Lighting management should make our customers' luminaires more flexible with easier system integration. But can it be easier? Yes, when mounting our DALI module, there are only 2 screws required and a single connector. ■

## Adura LED Solutions Introduces a Cuttable 4-ft Linear Module

Adura LED Solutions, a leading developer and manufacturer of LED lighting modules in Corona, California, is introducing its new platform of linear MCPCB and invites LED lighting fixture companies to experience the best performance Low Cost linear modules.

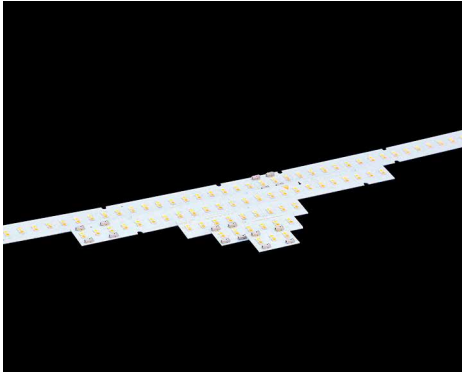

Adura 12423-A LED modules are available as white or color linear modules in different lengths, and they are cuttable down to 1.5 inches

### Product Features:

- Made-in-California at Adura, a UL Certified Manufacturing Facility
- Color tuning, 2 channel, cuttable linear module
- Linear 47.7 inch long LED module
- Cuttable at various lengths (1.5, 3, 4.5, 6, 9, 12, 24, 36 inches)
- High Efficiency Linear Modules
- Forward Voltage: 18 V, +/- 1.5 V
- Typical 2000-2400 lumen/ft.
- Excellent thermal management using Metal Core MCPCB for maximum heat dissipation
- Tight LED pitch to eliminate pixilation, no complex lens or optics required
- 3 Step MacAdam binning
- Wide CCT ranging from 2700-6500 K
- CRI options of 80+, 90+
- End to end mounting for long linear application
- Input and Output Poke-in connector for easy wiring
- LM-80 LEDs, Long life-time: > 50,000 hours
- Recognized UL PCB and Components

The Adura 12423-A LED white or color linear module designed with people and linear lighting applications in mind. The module is constant current, cuttable at various lengths and offered with 80+ and 90+ CRI options. With a

nominal 18 V forward voltage, long runs are even more achievable at distances specified down to the 1.5 inches.

### Specification:

The Linear modules are available in sample or production quantities and can be purchased directly from Adura LED Solutions. Designed and manufactured in Corona, California, the Linear modules are available in three different lengths. ■

## Code Mercenaries Releases DMX/RDM to DALI Bridge

Code Mercenaries is proud to introduce its LED-Warrior16, a DMX/ RDM to DALI bridge. The LED-Warrior16-DR converts DMX/RDM lighting control data into DALI commands. This allows controlling of DALI luminaires from a DMX/RDM bus. The LED-Warrior16 comes in an enclosure for mounting on a DIN rail. It requires a 7 V to 26 V DC power supply with 30 mA max.



Code Mercenaries new LED-Warrior16, a DMX/ RDM to DALI bridge enables installations in which DALI luminaires are to be controlled via a DMX/RDM bus

### Technical Data:

- DMX/RDM to DALI bridge
- Broadcast, group, or individual addresses
- 1 to 16 groups, 1 to 64 individual addresses
- 7 - 26 V power required, max. 30 mA
- Enclosure for DIN rail mounting

LED-Warrior16 converts the brightness data from the DMX/RDM bus into commands for the DALI bus. Either individual DALI luminaires, groups or all luminaires on the DALI bus can be addressed. 1 to 16 groups, or 1 to 64 individual

luminaires can receive their individual brightness value.

Configuration of LED-Warrior16 is done via the bidirectional RDM protocol. Standard tools may be used to do this. Start slot, mode and number of groups or luminaires are configurable.

### Quick Installation:

To install the LW16-DR on a DIN rail just gently push it onto the rail until it locks. No tools are required for mounting. Removing LW16-DR from the DIN rail is done by gently pulling one of the locking levers using a screwdriver or similar tool.

Connecting to the DALI bus is done via the terminal blocks. There are two positions in each of the blocks. The positions in a block are identical and intended for easy daisy chaining. Connect the DALI bus lines one to each of the blocks. LW16-DR needs a DC power of 7 V to max. 26 V at max. 30 mA. The DC power is connected to "V+" and "Gnd". Observe the polarity!

The DMX/RDM bus is connected to the terminals "Sig+" and "Sig-". Observe the polarity of the signal! The bus termination should be enabled if LW16-DR is the last device on the bus. To do this, insert a jumper between "Sig+" and "Term". Attention: None of the signals of LED-Warrior16-DR may be connected to mains voltage!

### Simple Configuration:

Configuration of LW16-DR is done via the RDM bus with any standard RDM configuration tool. The start slot and personality settings control the behavior of LW16-DR. The start slot selects the first DMX/RDM data slot that gets converted to DALI. The personality allows for the selecting of the number of slots to be used and which addressing mode is to be used.

Factory setting is that LW16-DR uses the first slot and converts it into a broadcast command. So in this mode all DALI devices are set to the brightness defined by the first slot.

Alternatively 1 to 16 slots can be used to control the DALI groups, or 1 to 64 slots to control the individual DALI devices. The first slot always goes to the group 0 or device zero, the next slots go to the next groups/ devices until the maximum number selected by the personality setting. ■

## Tridonic's LED Drivers with DALI Power Supplies for Flat Stylish Luminaires

With a height of only 11 or 16 mm the new drivers in the premium series (PRE) from Tridonic give luminaire designers enormous freedom to create versatile luminaire designs. In addition to the usual wide dimming range and one4all interface there are versions with an NFC interface. The 16 mm versions also have an integrated DALI power supply (po4a).



**The ultra-low-profile drivers are equipped with NFC interfaces for simple wireless programming. The integrated DALI power supply (po4a) on the 16 mm versions allows easy integration of sensors without the need for additional DALI lines**

The reduced low-profile housings have the same length and width as before (360x30 mm) but are now only 11 or 16 mm high instead of 21 mm. They offer virtually flicker-free dimming (<5%) of the connected luminaires from 100 to 1 percent and are equipped with smart interfaces such as NFC (Near Field Communication) and integrated po4a DALI power supply. The combination of NFC and the companionSUITE software package enables the drivers to be quickly and wirelessly programmed during the production process at luminaire manufacturers. Complete packaging units of up to 10 items can be wirelessly configured in a single pass via an antenna. The po4a interface (extended one4all Interface) supplies sensors with power and thus simplifies implementation of sensor-controlled lighting solutions. Additional DALI lines for the sensor are no longer necessary.

### Flexible setting options:

Typical applications for the slim drivers in low-profile housings are linear and area lighting systems in the office environment. They are also suitable for safety lighting in accordance with EN 50172. Common to all the drivers are application-optimized operating windows for maximum compatibility,

high energy savings thanks to low stand-by losses (<0.15 W) and high efficiency (>92%). The drivers are available in both heights with outputs of 50 and 75 W, in each case with adjustable output currents of 100 to 400 mA. There are four options for adjusting the output current: wirelessly via NFC using the web-based Tridonic companionSUITE software, via DALI using masterCONFIGURATOR, with the appropriate I-SELECT 2 plug resistor or via the ready2mains programmer. ■

## Inventronics - Narrow Input, CV Drivers Offer Significant Cost Savings

Inventronics is pleased to announce the expansion of their constant-voltage EBV Series to include 75 W, 100 W and 150 W models that operate at a narrow input voltage range from 176-305 Vac.

Narrowing the input voltage range has allowed Inventronics to reduce manufacturing costs and offer significant savings to regions that do not require a universal input voltage range. This series of LED drivers are made with a compact, extruded-metal housing enabling more creative freedom on luminaire design. They are IP67 rated which is ideal in architectural, decorative and signage lighting projects.



**Inventronics' latest constant-voltage LED drivers are designed for narrow input for regions that do not require a universal input to significantly reduce costs**

The EBV-075SxxxSV series provides output voltages of 24 V, 36 V and 48 V and supply up to 75 W at output currents from 0-3.2 A with a full-load efficiency up to 90%. The calculated lifetime of these drivers at 70°C case temperature is 97,000 hours.

The EBV-100SxxxSV series provides output voltages of 12 V, 24 V, 36 V and 48 V and supply up to 100 W at output currents from 0-8.4 A with a full-load efficiency up to 92%. The calculated lifetime of these drivers at 70°C case temperature is 85,000 hours.

The EBV-150SxxxSV series provides output voltages of 12 V, 24 V, 36 V and 48 V and supply up to 150W at output currents from 0-10 A with a full-load efficiency up to 91.5%. The calculated lifetime of these drivers at 70°C case temperature is 83,000 hours.

All three EBV Series provide a higher input surge protection with 4 kV line-to-line and 6 kV line-to-earth and incorporates many added protections such as over-current protection, over-voltage protection, short circuit protection and over-temperature protection.

The EBV-series is approved to CE, CB, ENEC, CCC, BIS and KS standards. They provide SELV output, are suitable for independent use. This series is not suited to be used in North America due to the narrow input voltage range. Production quantities of these drivers are available now. ■

## EuControls Zigbee Compatible Outdoor NEMA Lighting Controller

EuControls is excited to announce the addition of its latest wireless lighting controller to its growing lighting controls product portfolio. The new ECM-20-ZB is a 20 A rated 100 277VAC Zigbee compatible lighting controller intended for plug-and-play installation on outdoor area lighting fixtures containing NEMA twist-lock receptacles (ANSI C136.41-2013 standard). Fully Zigbee compliant on/off and dimming control is supported, and the controller's built-in north-facing photo sensor can enable daylight harvesting via gateway control or failover to predetermined on/off behavior based on luminous set points if connection with the gateway is lost.



**EuControls' ECM-20-ZB is a 20 A / 100-277 VAC rated, fully Zigbee and 100% NEMA compliant lighting controller for outdoor applications**

The ECM-20-ZB works with Current by GE's Daintree Networks' ControlScope platform



and Autani's EnergyCenter platform, as well as other Zigbee HA 1.2 compatible gateways capable of energy management strategies.

UL listed and designed for long-term reliability, the controller uses a zero-crossing **relay for safer operation**. The **ECM-20-ZB is also IP66 rated** rain-tight and can operate in extreme temperatures from 40 to +50 °C, allowing for use in parking lots, pathways, and other outdoor areas. ■

## GlacialPower Launches New GP-TH120N-24V LED CV Driver with TRIAC Dimming

GlacialPower, the power division of the LED technology manufacturer GlacialTech Inc, announces the new GP-TH120N-24V LED constant voltage driver. It is available in 24 V DC output rated power of 120 W. The driver supports TRIAC dimming function, and appropriates for LED strip applications in places such as restaurants, jewelry shop, home and theater.



GlacialPower's new GP-TH120N-24V LED constant voltage driver allows TRIAC dimming for LED strip applications

### Features:

- AC input range from 205 to 256 V AC
- Constant voltage mode
- Work with leading edge and trailing edge TRIAC dimmers
- AC phase-cut dimming
- IP67 rated
- Class I power unit, with FG
- Safety protections include OVP, OCP, SCP, and OTP
- Appropriate for 24V LED strips application
- 3 Years warranty
- RoHS compliant

The dimming adjustment output of the GP-TH120N-24V LED driver ranges from 1% to 100%. Works with leading edge and trailing edge TRIAC dimmers. The typical power conversion efficiency is 84%. It supports an AC input voltage range from 205 to 256 VAC.

The fully isolated case design enables an operation temperature range of -20°C to 50°C, which means that the LED driver can be used in most environments. Additionally, with IP67 approval as well as four different protections: Over-Voltage Protection (OVP), Over-Current Protection (OCP), Short-Circuit Protection (SCP) and Over-Temperature Protection (OTP), these drivers are highly secure.

# GL OPTIC

## Spectral light measurement for lab and production

Precise light measuring of LED lamps and lighting to international standards.

[www.gloptic.com](http://www.gloptic.com)



## ix-led

In order to meet every demand, we have 1,500 innovative LED product developments ready for you.

Our passion is creating new solutions every day - for your applications, too.

Order your sample now:  
[www.mal-effekt.de/sample](http://www.mal-effekt.de/sample)

m.a.l. Effekt Technik GmbH | Wiesenweg 6 | 36179 Bebra  
Phone +49 (0) 6622 9133-0 | [info@mal-effekt.de](mailto:info@mal-effekt.de)

Made in Germany

**m.a.l.**  
modern.art.of.light.

## Inventronics Expands Cost-Effective, Programmable LED Driver Family

Inventronics has expanded their EUK family of programmable, constant-power and IP67 LED drivers to include models at power levels of 320 W. These new models are in addition to already extensive power level range that includes 75 W, 96 W, 150 W, 200 W and 240 W models. The EUK family is well suited for applications that do not require enhanced features such as always-on auxiliary power, controls-ready features or multiple timer dimming capabilities. By optimizing the features including isolated 0-10 V and 10 V PWM dimming, there is now a more cost-effective product that still offers design flexibility, high efficiency and a reliable performance.



**Inventronics offers two EUK driver versions: The EUK-320SxxxDT and the EUK-320SxxxDV. The main difference between them is that the EUK-320xxxDT is UL dry, damp, wet location approved**

### Main Features:

- Programmable, enabling hundreds of configurations
- Constant power at a wide output current range
- Dimming controls: Isolated, 0-10 V, 10 V PWM
- Input surge protection: 6 kV DM, 10 kV CM
- SELV output
- UL dry, damp, wet location (DT Version only)
- TYPE HL, for use in a Class I, Division 2 hazardous location

The EUK-320SxxxDT and EUK-320SxxxDV operate from 90-305 Vac input and the rugged, extruded-metal housing is IP67 rated which is ideal for harsh indoor and outdoor conditions such as high bay, high mast and sports/arena lighting. Each series offers five, constant-power, programmable models delivering 320 W at output currents from 1050 mA to 6700 mA including SELV output.

The EUK-320SxxxDT is suitable for use in North America and offers TYPE HL, for use in a Class I, Division 2 Hazardous Location. The EUK-320SxxxDV is suitable for use in Europe and other regions for built-in independent use.

The EUK-320 series is highly reliable with a superior level of built-in surge protection (6 kV DM, 10 kV CM). Additional protection features include: over-voltage, over-temperature, and short-circuit protection. The lifetime of these drivers is calculated to be at least 86,000 hours when operating at 80% load.

This new family is approved to UL, FCC, CE, ENEC, TUV, CB, CCC, PSE, KC, BIS and RCM certifications. Production quantities of the EUK-320SxxxDT and the EUK-320SxxxDV are available now. ■

## Upgrade for Emergency Lighting Components Provides Smart Battery Management

Tridonic has further developed its emergency lighting units. The new generation EM converterLED BASIC MH/LiFePO<sub>4</sub> in the low-profile housing now supports not only NiMH but also LiFePO<sub>4</sub> batteries and operates with intelligent battery management.



**Tridonic's EM converterLED BASIC MH/ LiFePO<sub>4</sub> can be equipped with either NiMH or LiFePO<sub>4</sub> batteries. The charge algorithm automatically adapts to the battery type**

The new generation of the EM converterLED BASIC MH/LiFePO<sub>4</sub> emergency lighting units in the low profile housing has been designed for luminaires with single battery systems. In addition to nickel metal hydride batteries (NiMH), the units can now also be operated with lithium iron phosphate batteries (LiFePO<sub>4</sub>). Smart battery management ensures that the right charging algorithm is used for the particular battery type. The

batteries therefore achieve their optimum operating life and at the same time the maintenance requirements are reduced.

### For LED modules from 10 to 250 V:

There are versions available for LED modules with voltages of up to 50 V (SELV), up to 90 V and up to 250 V, which means that the emergency lighting units can be used with a high degree of flexibility over a wide range of voltages. They can be combined with all dimmable and non-dimmable constant-current LED drivers. The rated operating time is one or three hours and can be set via Duration Link. The output power remains constant.

The units operate in standby mode and are designed for manual testing. An optional test button is available for checking the function of the unit. The expected life is four years for NiMH batteries and four to eight years for LiFePO<sub>4</sub> batteries. The manufacturer provides a guarantee of one to three years. The life of the lighting unit is 50,000 hours. The manufacturer provides a 5-year guarantee for the emergency lighting unit. ■

## Tridonic's New LED Drivers Have basicDIM Wireless Module Directly Integrated

Tridonic has now equipped its new LED drivers in the premium (PRE) series with the basicDIM Wireless module. Quick, convenient, space-saving wireless lighting control is now possible.

The new LED drivers in the premium (PRE) series with an integrated basicDIM Wireless module use Bluetooth technology to achieve wireless communication with up to 127 devices in a network.

There is no longer the need for a separate wireless module to control luminaires wirelessly. All that is required for each luminaire is a driver in which the basicDIM Wireless module is already integrated. Luminaires equipped in this way can be controlled, assigned to luminaire groups and faded up and down between 1 and 100%, all via Bluetooth. It is also possible to set up lighting scenes or, with suitable drivers, create tunable white applications. The output currents can be easily set via the I-SELECT 2 plug.



Tridonic's three different versions of the drivers with an integrated basicDIM wireless module, cover a broad spectrum of applications in a wide range of luminaire types

Three versions of this Casambi Ready driver are available, covering a wide range of luminaire types:

- The SC PRE (CC) basicDIM Wireless constant current driver comes in four models ranging from 10 W to 45 W (150 mA 1,400 mA). They are suitable for luminaire installation or for installation as separate drivers with optional strain relief, for example, together with the SLE, CLE or DLE LED modules. Depending of the model, the output power is 10 W, 17 W, 25 W or 45 W
- Also available in four models, from 35 W to 150 W is the basicDIM Wireless 24 V constant voltage LED driver PRE (CV) in miniature form with strain relief. They are compatible, for example, with the LLE FLEX modules. Depending on the model, the output power is 35 W, 60 W, 100 W or 150 W
- The Tunable White PRE (TW) LC 38W 2 CH DT8 basicDIM Wireless driver is a separate two-channel constant current driver with an output power of 38 W

The new PRE drivers will be of particular benefit to operators of offices, healthcare practices and shops looking for a quick and convenient way to modernize their lighting without any new cabling. They will then have a powerful, low-cost light management system that can be easily controlled via Bluetooth. For ultimate ease of use there is the free App 4remote BT app and optional user interface. ■

## Dow Announces New, Cost-Efficient DOWSIL™ EI-2888 Primerless Silicone Encapsulant

Dow, a global leader in silicones, silicon-based technology and innovation, has unveiled DOWSIL™ EI-2888 Primerless Silicone Encapsulant, an optically-clear

silicone for professional LED lighting that cures at room temperature. This advanced silicone technology provides superb optical performance without compromise and offers unique rheological properties for use with light fixtures in a variety of shapes and forms. Designed for explosion proof and high ingress protection rated luminaires, DOWSIL™ EI-2888 Primerless Silicone Encapsulant is also cost-effective to buy and use.



DOWSIL™ EI-2888 combines primerless adhesion with inhibition resistance, optical clarity, low viscosity, and UL 94 compliance in a 100% silicone (PDMS) formulation, solving processing and cost challenges

"LED luminaires in harsh environments need protective materials that are reliable, easy to apply, and that provide robustness of cure," said Konstantin Sobolev. "DOWSIL™ EI-2888 Primerless Silicone Encapsulant eliminates a time-consuming processing step and reduces waste that can occur if curing is compromised by surface contaminants or moisture. This low-viscosity silicone also dispenses readily and adheres reliably without sacrificing optical properties. DOWSIL™ EI-2888 Primerless Silicone Encapsulant is an excellent choice for many professional applications, including explosion proof lighting, outdoor displays, and flexible and rigid LED strips."

A two-part protective material with a 1:1 mix ratio, DOWSIL™ EI-2888 Primerless Silicone Encapsulant cures at room temperature with optional heat acceleration. This UL 94 compliant, 100% polydimethylsiloxane (PDMS) silicone provides even curing and is insensitive to inhibition, a typical issue for platinum catalysts; and material reversion, a traditional problem in enclosed spaces at high temperatures. DOWSIL™ EI-2888 Primerless Silicone Encapsulant can be applied with automated static or dynamic metered mixing, manual mixing, or with flow, pour or needle dispensing equipment. This novel self-priming encapsulant adheres to a variety of substrates and supports the design of innovative LED luminaires in IP-rated enclosures. ■

## Improve Quality Control with Tagarno's Apps for Your Digital Microscope

Finding the right equipment for quality control can be time consuming. That's why it is important to find long lasting and agile equipment. One solution is a digital microscope with quality control improving apps that allows the operator to alter the system to meet future requirements without investing in new equipment.



With Tagarno's apps for your digital microscope, you don't have to purchase new quality control equipment if your processes and requirements change

Among the apps developed by Tagarno are:

- Image Comparison that allows the operator to compare a reference image of a golden sample with a recent sample from the production line
- Focus Stacking that stacks images taken at different focus heights to create one ultra-sharp image with no blurred or out of focus areas
- Tagarno Measurement application that enables the operator to perform on-screen measurements and add annotations and text to the image directly on the microscope
- Watermark that allows the user to brand an image with a logo or confidential text. It is also possible to add date, time, field of view plus microscope name and serial number as an imprint on the image
- Verification Lines that enables the operator to quality check an object by placing accurately calibrated vertical and/or horizontal lines as a layer on top of it

With a digital microscope from Tagarno, the user can purchase apps specifically developed to improve quality control processes for their microscope. This gives the operator access to the latest technology without having to invest in new microscopes all the time.

With a digital microscope, you can easily capture and share images of your work - both with and without graphics on.

The shared documentation material allows for improved collaboration with all supply chain partners and more efficient quality control. ■

## Brilliance & Intensity - Nimbus Modul Q also with Bartenbach Reflector Technology

Nimbus is now presenting Q ONE, Q FOUR and Q FOUR TT the new generation of the Modul Q family of ceiling luminaires featuring a wallwasher. The focused light enables the realization of defined lighting zones and the accentuation of surfaces and spaces.



**Nimbus Q ONE, a glare-free wall spot with Bartenbach reflector technology, is perfect for highlighting large-format paintings (Photo credits: DesignRaum)**

The Modul Q family is used in living spaces including the kitchen in galleries, medical practices and in restaurants. The compact modules are made of aluminum and are available in matt black or matt white. They have built-in lenses with either one or four high-performance LEDs.

The new generation of Nimbus Modul Q luminaires provides warm, directed light with excellent light quality. Available in either black or white, the compact, minimalistically designed body of the luminaire retreats completely into the background.

In contrast to the proven Nimbus Q modules so popular with designers which are still used for general lighting Modul Q One, Q Four and Q Four TT provide pinpoint accentuating light with a precise beam angle of 40° or 80°. "The new products complete our kit for lighting designers," says Dietrich F. Brennenstuhl, the Nimbus CEO. As light sources, they retreat completely into the background and blend in with the wall or ceiling. Their true lighting effect comes to the fore on the surface to be illuminated tables, work surfaces, counters and objects.

Dietrich F. Brennenstuhl characterizes the high-quality lighting effect thus: "The light emitted is of extraordinary brilliance. The intensity and power with which it strikes surfaces and objects come as something of a surprise while at the same time one is also impressed by its warmth and coziness." ■

## Osram Provides Special Grow Light System for Horticulture Research

Osram has developed a research luminaire to meet the growing demands of researchers at universities, private institutes in greenhouses and vertical farms. Researchers and modern agriculturists can use the LED-based plant luminaire system Phytogy RL in the lab or in climatic chambers in order to develop new plant-specific light and growth recipes. These recipes can lead to desired outcomes in plant quality, yield and flavor.



**Use of Phytogy RL allows the researchers to evaluate the most varied light recipes, without having to change luminaires between individual tests (Picture credits: Osram)**

Various light wavelengths and intensities allow selective intervention in the metabolic processes of agricultural crops and ornamental crops. Yield, coloration and taste as well as other features can be influenced in this way. The latest research shows that not only is this process impacted by photosynthetically active radiation (PAR) in the range of 400 to 700 nanometers (nm) - but that shorter and longer wavelengths also influence plant development.

With Phytogy RL, six spectral channels from a natural far-red end-of-day light to UV light can be addressed individually and the photosynthetic photo flux density (PPFD) planned and controlled precisely in real time: 385 nm, 450 nm, 521 nm, 660 nm, 730 nm as well as a warm white channel with 2,700 Kelvin. At the same time, the large number of LEDs in the fixture allows a higher photosynthetic photon flux (PPF).

A special feature of the system is its highly uniform light distribution. The calibrated system furthermore supplies a precise irradiance map, calculated by the software with no quantum flux measurements required. Use of Phytogy RL allows for evaluation of the most varied light recipes, without having to change luminaires between individual tests. Diverse combinations of wavelengths also can be programmed, in different light profiles and across the entire photoperiod. In addition, users get five light recipes following registration, which have been specially developed by Osram.

The system software was developed by Osram together with plant biologists and can be used intuitively via the graphical user interface. Manufacturers of climate chambers benefit too, with integration possible in their systems. The flat and robust design (667x299x44 mm, just under 9 kilos) is optimized for vertical farms, rack systems and growth chambers.

Phytogy RL is already being used by NASA and Michigan State University. Osram is using it to carry out research of growth, anthocyanins and taste, conducted in a climate chamber at the TU Munich. ■

## WAC Lighting Aether 2" - Extreme Shallow LED Recessed DownLight

WAC Lighting unveils the Aether 2" Extreme Shallow Recessed Down Light, a "Next-Level down light" which features a low profile LED housing that is designed to fit in very tight plenum spaces without compromising lumen output or glare control. Aether provides general accent and wall wash illumination in a wide range of indoor and covered outdoor space applications in residential, commercial, hospitality and architectural environments.



**WAC Lighting's Aether is CEC Title 24 compliant and wet location listed**



CREE® XLAMP® LEDs



CREE® HIGH-BRIGHTNESS LEDs

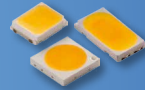

CREE® J SERIES™ LEDs

BARRIER-BREAKING, GAME-CHANGING, INDUSTRY-LEADING—WE MAY RUN OUT OF ADJECTIVES, BUT

# WE'LL NEVER RUN OUT OF INNOVATION

SEE THE COMPLETE PORTFOLIO AT: [CREE.COM/LED-COMPONENTS](http://CREE.COM/LED-COMPONENTS)



Delivering versatile and contemporary lighting for virtually any space, the compact 2" luminaire accommodates ceilings with just one-half to one-inch thickness. This recessed down light is ideal for the clean minimalist expression that is preferred in newly constructed modern buildings today. With features such as vertical and horizontal adjustment, choose from round or square, trim or trimless, and an array of finishes.

The IC rated, airtight universal housing accepts three types of trim: a down light for general illumination with superior glare control; an adjustable accent light with 0-25° index-based precision aiming; and a wall washer that illuminates with an innovative patterned lens.

The luminaire uses just 15 watts while delivering up to 1405 lumens. It offers a CCT ranging from 2700 K to 4000 K with 17° spot to 50° wide optics.

The extreme shallow recessed down light minimizes a loss of ceiling height when using furring strips. Its gated access door is designed for installation below the ceiling line. Trim or Trimless styles are available.

The 120-277 V Universal Voltage driver dims down beautifully to just five percent, with ELV, TRIAC or 0-10 V dimming capabilities. The LEDs have a 50,000-hour rated life. ■

## Healthe Launches Line of Architectural Luminaires

Healthe® by Lighting Science is pleased to announce the launch of its circadian optimized line of architectural luminaires. The product line, named 480®, leverages Healthe's patented technology to deliver the right spectrum at the right time, enhancing wellbeing and productivity in commercial, managed care, hospitality and many other applications. Available in a variety of linear profiles, mounting options, and lengths, the 480 line can be specified in nearly any type of configuration.

The 480-product line takes its name from the wavelength of light that corresponds to the body's peak circadian sensitivity. Blue-enriched light at 480 nanometers provides an alertness-boosting impact akin to that of natural sunlight while blue-depleted

light at 480 nanometers creates a more calming environment. The 480 series luminaires, with their engineered spectrum, optimize circadian impact. The two-channel light source includes the alertness and focus-enhancing GoodDay® spectrum and the blue-depleted GoodNight® spectrum that enhances sleep. Source spectrum and intensity are controlled via 0-10V inputs, thus enabling easy integration with buildings' control systems.



**Healthe's new series of circadian fixtures is a wellbeing solution for the built environment**

"The 480 line is about simplifying circadian lighting and making it more accessible for architects and specifiers," says Meggan Kessler, VP Product Management and Marketing of Healthe. "With the 480 Line, Healthe enhances its position as a leader in the wellness space, using light as a platform to deliver beneficial solutions for the built environment. The era of installing LED solutions to only achieve energy savings has passed. The 480 line brings the comfort and health of occupants back as the top priority."

The 480 family of products come in varying profiles, lengths, and mounting configurations including suspended, wall mount, surface and recessed. This substantial offering of products ensures that designers will have all the relevant form factors required to include an element of circadian supporting, biological light in any of today's built environments. ■

## Plessey's New Hyperion Inter Light Complements Existing Top Lighting

Plessey announces the launch of its new Hyperion Inter Light. The latest launch from Plessey's Hyperion Grow Light brand comes after the growing success of its Hyperion top light range which saw over 10Ha of grow light installations in 2018.



**Hyperion Inter Light is designed to perfectly supplement the existing HPS&SON-T top lighting products**

Plessey's Hyperion Inter Light is the perfect partner to the Hyperion top light range or to supplement existing HPS/SON-T top lighting. The Inter Light fixture has been specifically designed to provide intra-canopy light from state-of-the-art LEDs for high wire cultivation of greenhouse vegetables and is installed within the crop to supplement existing top lighting.

The Inter Light is suitable for use in hybrid systems with HPS and LEDs, promoting plant growth and fruit ripening speed. With a choice of light outputs and efficacy to suit different growing environments, the Inter Light also provides wide beam angle for optimum light penetration.

With up to 300  $\mu\text{mol/s}$  light output and 3  $\mu\text{mol/joule}$  efficiency, greenhouse growers can boost production by applying the right light at the right spot with the durable aluminum lightweight IP66 unit profile.

The Inter Light system comes with competitive pricing as well as an industry leading 5-year warranty. Installation is simple and cost-effective with plug and play connections, daisy chaining up to 20 fixtures together and simple mounting on wires that can be raised and lowered.

The Inter Light hangs within the canopy of high wire crops, providing increased light at optimized spectra and also acts as an extra heating pipe to deliver higher yields from less energy. ■

## Formalighting, Casambi and LensVector Take LED Lighting to the Next Level

Formalighting, a leader in motorized architectural lighting products, has introduced luminaires that make aiming, directing, and shaping light easier and faster

to configure and adjust. Working together with LensVector, a specialist in Dynamic Beam Shaping™ technology and Casambi, the market-leading developer of wireless lighting control systems based on Bluetooth Low Energy (BLE), Formalighting's new luminaires prove the longstanding expectation, that solid-state lighting capabilities will exceed those of the previous generation of light sources.



Casambi and LensVector technology in Formalighting's Motolux product family are used to produce the first motorized luminaire with dynamic beam shaping and smart wireless controls

Michael Monsonogo, General Manager of Formalighting, commented: "We are delighted to be introducing the world's first motorized luminaire with LensVector's Dynamic Beam Shaping and Casambi's smart wireless control technology. We believe in utilizing the most exciting new technologies to address the design challenges faced by lighting professionals."

For the first time, lighting designers and electrical consultants can effortlessly add new lighting effects to projects by using the new fixtures in Formalighting's MOTOLUX range. The integrated technology within the motorized luminaires offers smart control over the beam angle, movements of the fixture, as well as the intensity and the white color tuning of the light.

LensVector's Dynamic Beam Shaping technology turns liquid crystal molecules into a series of modifiable micro-lenses. The technology delivers unmatched precision beams and dynamic dramatic effects. It allows the beam from MOTOLUX luminaires to be adjusted along a continuum from a less-than-ten-degree narrow spot angle to a very wide 50-degree flood, flowing fluidly through all the all points in between.

Casambi's wireless control technology enables lighting designers to take advantage of the full featured professional lighting

control platform Casambi provides as well as the fast-growing range of "Casambi ready" control devices (including sensors and switches) from an ever-growing list of leading manufacturers.

Brent York, President and CEO of LensVector, commented: "The marriage of great design and technology allows MOTOLUX users to precisely control the beam of light in a simple and convenient manner via Bluetooth app on their smartphone. We're excited to see how the LensVector technology is being applied to add value to LED luminaires."

Casambi's CEO Timo Pakkala commented: "Casambi's market-leading position in wireless lighting control is demonstrated by this innovative lighting collaboration with Formalighting and LensVector. MOTOLUX is part of the growing community of Casambi-ready connected luminaires and supporting digital devices for professional lighting schemes used in retail stores, art galleries, restaurants and hotels, among other venues."

Created for environments needing frequent scene changes, MOTOLUX motorized fixtures will quickly and easily re-configure a space to meet the demanding requirements of end users. Eliminating the need for ladders and scissor lifts, the MOTOLUX range of track, pendant and recessed fixtures can pan and tilt, dim, dim to warm and change color temperature on command. They can be controlled individually or in groups with no special equipment, giving users a level of control and time savings that translate to cost savings.

The MOTOLUX product range from Formalighting is available to buy now. ■

## GlacialLight Announces New LED Searchlight of GL-BL150-SL Series

GlacialLight, the lighting division of GlacialTech Inc. announced a new energy efficient, powerful and durable LED searchlight. The GL-BL150-SL is a 147W searchlight for outdoor lighting applications with rugged IP66 rated weatherproof design. Featuring up to 13,200-lumen output, the GL-BL150-SL produces over one hundred thousand lux at 1-meter distance.



Glacial's latest development, the GL-BL150-SL searchlight, comes with a narrow 23 degree beam angle

### Features:

- Power consumption 147 W
- Up to 101,100 Lux at 1 m distance
- IP66 rated for outdoor use
- With a narrow 23° beam angle
- Default shipment with the safety wire, the bracket and screws are all stainless-steel

The GL-BL150-SL comes with a narrow 23 degree beam angle with higher lux and increased throw. As well as its structures with pure aluminum housing, stainless steel bracket and screws. The bracket available in 180 degrees rotating, it can adjust the projection angle in need. This new searchlight offers a safety steel wire mounted for default shipment. It is easy to install and the construction is robust. The GL-BL150-SL is suitable use in ancient buildings, bridges, museum, and building's walls. ■

## Access Fixtures - New "No Light Below 450 nm" Troffers for Clean Rooms and Production Facilities

Access Fixtures has released a new LED troffer that emits no UV and no light below 450nm. Named FLAT, the troffer was designed for grid ceilings of clean rooms and production facilities that require no UV and no light below 450 nm. Prior to the advent of FLAT, clean rooms and production facilities that required no-UV lighting relied on fluorescent lamps with coatings (gold lamps) or filtered lenses to block out UV wavelengths. However, coatings and filters broke down over time, causing expensive production failures. The LED technology developed by Access Fixtures renders gold lamps and filters obsolete.

With FLAT, there is no risk of filters failing because there are no filters. FLAT uses LEDs that do not emit UV and do not emit light

under 450 nm. Even better, FLAT emits the broadest spectrum no UV and no light under 450 nm lighting available. The light is also flicker-free and fitted with a cutting-edge diffuser. The flicker-free, diffused, broad-spectrum light will significantly enhance visibility compared to old gold lamps and filtered lighting solutions.

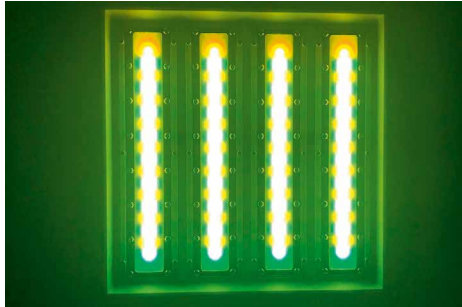

**Access Fixtures' new FLAT LED troffer emits no light below 450 nm and no UV. The LED technology renders gold lamps and filters of fluorescent lamps for clean rooms and production facilities obsolete**

With FLAT, there is no risk of filters failing because there are no filters. FLAT uses LEDs that do not emit UV and do not emit light under 450 nm. Even better, FLAT emits the broadest spectrum no UV and no light under 450 nm lighting available. The light is also flicker-free and fitted with a cutting-edge diffuser. The flicker-free, diffused, broad-spectrum light will significantly enhance visibility compared to old gold lamps and filtered lighting solutions.

Many research and production facilities either want to reduce energy use or are required to comply with regulations such as CA Title 24. FLAT is ready for most if not all controls including 0-10 V dimming, occupancy sensors, and DALI. FLAT is not affected by frequent on/off cycles or dimming.

Surface space in clean room and production facility ceilings is required for airflow, fire suppression systems and lighting. To date, troffers have typically required a 2' x 4' space in a grid ceiling. FLAT emits the light of a troffer equipped with four 32 watt T8 lamps and does so using only 2' x 2' of ceiling space. The broad beam optics and diffusers distribute the light so the light is even and there are no hot spots.

The FLAT is independently lab tested and prototypes have been tested by Fortune 500 companies.

Available in 7,800 and 10,400 lumen packages and able to operate on 120-277 V or 347-480 V power supplies, the LED technology in FLAT is exactly what managers want for clean rooms and production facilities. FLAT features extreme life and is rated L70 @ 200,000 hours virtually eliminating maintenance. FLAT troffers are IP67 rated which means that they completely sealed and even submersible. Optional 90-minute emergency battery backup meets safety requirements while maintaining the no UV and no light under 450 nm standard. FLAT luminaires are protected by a 5-year Access Fixtures warranty. ■

## EuControls Introduces Zigbee Compatible High Bay Occupancy Sensor

EuControls is excited to announce the addition of a high bay occupancy sensor to its growing wireless lighting controls product portfolio. This Zigbee compatible energy management device is ideal for new and retrofit lighting projects that require occupancy-based, multi-level lighting control at the fixture level.



**EuControls' S708-P-DZB is a self-contained PIR motion and light sensor with line voltage relay**

The S708-P-DZB is a self-contained PIR motion and light sensor with line voltage relay designed for installation on the side of a lighting fixture via a conventional 1" knockout. Commissioning and adjustment of sensor operation are made via gateway software such as Current by GE's Daintree Networks' ControlScope Manager and the Cortet Lighting platform, as well as other Zigbee HA 1.2 compatible gateways capable of energy management strategies. The indoor device includes an integrated photodiode that also allows programming of daylight harvesting functionality, further increasing energy savings.

This 0-10 V dimming sensor can be installed on fixtures mounted at 40' in warehouses, conference halls, sports facilities, hallways, and other large spaces. An optional, interchangeable low bay lens is available, providing a 13' detection radius at a 10' mount height. UL listed and engineered for long-term reliability, the S708-P-DZB uses a zero-crossing AC relay for safer operation. All sensors from EuControls are protected by a 3-year limited product warranty. ■

## Hidden in Light Rails - Tridonic LED Drivers Don't Need a Trackbox

With the in-track drivers in the advanced and excite (ADV/EXC) series, Tridonic is continuing with the miniaturization of its control gear. The drivers have an output power of 25 or 40 W and are integrated directly in the adapter for the 230 V track systems so there is no longer any need for a trackbox.



**Tridonic's advanced and excite in-track LED drivers can be invisibly integrated in 230 V power track systems**

The in-track ADV and EXC (SELV) drivers show their strengths when used in lighting for shops, art galleries, museums and restaurants. Their compact design enables them to be installed directly in an adapter (available in black or white) which can be hidden in a 230 V track system to save space. The conspicuous trackbox that was previously required is now superfluous. This opens up design options in which technology can take a backseat in favor of more subtle designs for the luminaires.

### Flexible combinations with LED spotlight modules:

Thanks to the wide operating window of 350 to 600 mA for devices with an output power of 25 W and 500 to 1050 mA for devices with an output power of 40 W, the in-track drivers can be combined with numerous LED



spotlight modules. On drivers in the advanced series the relevant output currents can be easily set in 25 mA increments via an I-SELECT 2 plug. Drivers in the excite series can be set in 1 mA increments via NFC. With NFC multiprogramming and the in-house companion SUITE software, up to 10 packaging units can be programmed in a single step. This speeds up the configuration process in production, lowers costs and reduces the error rate. The output current can be easily changed at any time via NFC.

The in-track drivers offer excellent performance with more than 85 percent efficiency at a favorable price-performance ratio. They are compatible with the Global Trac PRO and Global Trac PULSE track systems from Nordic Aluminium, as well as with OneTrack from Stucchi. ■

## An Old Story Re-Edited? - Firefly-Inspired Surfaces Improve LED Efficiency

A new type of light-emitting diode light bulb could one day light homes and reduce power bills, according to Penn State researchers who suggest that LEDs made with firefly-mimicking structures could improve efficiency.

This news went viral at the end of February. After deliberating what to do with it, we decided to publish it with some remarks.

We are doing this because readers of LED professional might remember a similar story from 2013 ([www.led-professional.com/technology/light-generation/scientists-mimic-fireflies-to-make-brighter-leds](http://www.led-professional.com/technology/light-generation/scientists-mimic-fireflies-to-make-brighter-leds)).

The 2013 article leads to the following questions: :

- What is new and has something relevant changed since 2013?
- Will the approach really be applied this time or is it already obsolete?
- Isn't this approach or a better solution already applied in the industry?

Read both articles and let me know what you think at: [a.g-m@led-professional.com](mailto:a.g-m@led-professional.com)

Fireflies and LEDs face similar challenges in releasing the light that they produce because the light can reflect backwards and get lost. One solution for LEDs is to texture the surface with microstructures - microscopic

projections - that allow more light to escape. In most LEDs these projections are symmetrical, with identical slopes on each side.

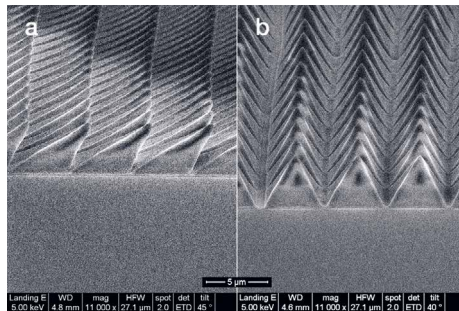

Scanning electron microscope images of the 3-D nanoprinted asymmetric (a) and symmetric (b) pyramids (Image credits: Penn State)

Fireflies' lanterns also have these microstructures, but the researchers noticed that the microstructures on firefly lanterns were asymmetric - the sides slanted at different angles, giving a lopsided appearance.

Using asymmetrical pyramids to create microstructured surfaces, the team found that they could improve light extraction efficiency to around 90 percent. The findings were recently published online in *Optik* and will appear in the April print edition.

According to Yin, asymmetrical microstructures increase light extraction in two ways. First, the greater surface area of the asymmetric pyramids allows greater interaction of light with the surface, so that less light is trapped. Second, when light hits the two different slopes of the asymmetric pyramids there is a greater randomization effect of the reflections and light is given a second chance to escape.

After the researchers used computer-based simulations to show that the asymmetric surface could theoretically improve light extraction, they next demonstrated this experimentally. Using nanoscale 3D printing, the team created symmetric and asymmetric surfaces and measured the amount of light emitted. As expected, the asymmetric surface allowed more light to be released.

Two processes contribute to the overall efficiency of LEDs. The first is the production of light - the quantum efficiency, which is measured by how many electrons are converted to light when energy passes through the LED material. This part has already been optimized in commercial LEDs. The second process is getting the light out of the LED - called the light extraction efficiency.

In commercial LEDs, the textured surfaces are made on sapphire wafers. First, UV light is used to create a masked pattern on the sapphire surface that provides protection against chemicals. Then when chemicals are applied, they dissolve the sapphire around the pattern, creating the pyramid array.

"You can think about it this way, if I protect a circular area and at the same time attack the entire substrate, I should get a volcano-like structure," explained Chen.

In conventional LEDs, the production process usually produces symmetrical pyramids because of the orientation of the sapphire crystals. According to Chen, the team discovered that if they cut the block of sapphire at a tilted angle, the same process would create the lopsided pyramids. The researchers altered just one part of the production process, suggesting their approach could easily be applied to commercial manufacture of LEDs.

Researchers who worked on the project were Jimmy Yao, Wenbin Zhu, Ju-Hung Chao, Annan Shang and Yun-Goo Lee, doctoral students in electrical engineering. The researchers have filed for a patent on this research. ■

### References:

Original Article: [news.psu.edu/story/559722/2019/02/18/research/firefly-inspired-surfaces-improve-efficiency-led-lightbulbs](http://news.psu.edu/story/559722/2019/02/18/research/firefly-inspired-surfaces-improve-efficiency-led-lightbulbs)  
Original Study DOI: [doi.org/10.1016/j.ijleo.2019.01.043](https://doi.org/10.1016/j.ijleo.2019.01.043)

## A Possible Future of Lighting - Paint-On Semiconductors from Ornate Quantum Physics

LED lights and monitors, and quality solar panels were born of a revolution in semiconductors that efficiently convert energy to light or vice versa. Now, next-generation semiconducting materials are on the horizon, and in a new study, researchers have uncovered eccentric physics behind their potential to transform lighting technology and photovoltaics yet again.

Comparing the quantum properties of these emerging so-called hybrid semiconductors with those of their established predecessors

is about like comparing the Bolshoi Ballet to jumping jacks. Twirling troupes of quantum particles undulate through the emerging materials, creating, with ease, highly desirable optoelectronic (light-electronic) properties, according to a team of physical chemists led by researchers at the Georgia Institute of Technology. These same properties are impractical to achieve in established semiconductors.



Carlos Silva (l.) in his lab with graduate research assistant Félix Thouin examining a setup to process laser light in the visible range for the testing of quantum properties in a halide organic-inorganic perovskite (Credits: Georgia Tech / Rob Felt)

The particles moving through these new materials also engage the material itself in the quantum action, akin to dancers enticing the floor to dance with them. The researchers were able to measure patterns in the material caused by the dancing and relate them to the emerging material's quantum properties and to energy introduced into the material.

#### Unusually flexible semiconductors:

The emerging material's ability to house diverse, eccentric quantum particle movements, analogous to the dancers, is directly related to its unusual flexibility on a molecular level, analogous to the dance floor that joins in the dances. By contrast, established semiconductors have rigid, straight-laced molecular structures that leave the dancing to quantum particles.

The class of hybrid semiconductors the researchers examined is called halide organic-inorganic perovskite (HOIP), which will be explained in more detail at bottom along with the "hybrid" semiconductor designation, which combines a crystal lattice - common in semiconductors - with a layer of innovatively flexing material.

Beyond their promise of unique radiance and energy-efficiency, HOIPs are easy to produce and apply.

#### Paint them on:

"One compelling advantage is that HOIPs are made using low temperatures and processed in solution," said Carlos Silva, a professor in Georgia Tech's School of Chemistry and Biochemistry. "It takes much less energy to make them, and you can make big batches." Silva co-led the study alongside Ajay Ram Srimath Kandada from Georgia Tech and the Istituto Italiano di Tecnologia.

It takes high temperatures to make most semiconductors in small quantities, and they are rigid to apply to surfaces, but HOIPs could be painted on to make LEDs, lasers or even window glass that could glow in any color from aquamarine to fuchsia. Lighting with HOIPs may require very little energy, and solar panel makers could boost photovoltaics' efficiency and slash production costs.

The team led by Georgia Tech included researchers from the Université de Mons in Belgium and the Istituto Italiano di Tecnologia. The results were published on January 14, 2019, in the journal *Nature Materials*. The work was funded by the U.S. National Science Foundation, EU Horizon 2020, the Natural Sciences and Engineering Research Council of Canada, the Fond Québécois pour la Recherche, and the Belgian Federal Science Policy Office.

#### Quantum jumping jacks:

Semiconductors in optoelectronic devices can either convert light into electricity or electricity into light. The researchers concentrated on processes connected to the latter: light emission.

The trick to getting a material to emit light is, broadly speaking, to apply energy to electrons in the material, so that they take a quantum leap up from their orbits around atoms then emit that energy as light when they hop back down to the orbits they had vacated. Established semiconductors can trap electrons in areas of the material that strictly limit the electrons' range of motion then apply energy to those areas to make electrons do quantum leaps in unison to emit useful light when they hop back down in unison.

"These are quantum wells, two-dimensional parts of the material that confine these quantum properties to create these particular light emission properties," Silva said.

#### Imaginary particle excitement:

There is a potentially more attractive way to produce the light, and it is a core strength of the new hybrid semiconductors.

An electron has a negative charge, and an orbit it vacates after having been excited by energy is a positive charge called an electron hole. The electron and the hole can gyrate around each other forming a kind of imaginary particle, or quasiparticle, called an exciton.

"The positive-negative attraction in an exciton is called binding energy, and it's a very high-energy phenomenon, which makes it great for light emitting," Silva said.

When the electron and the hole reunite, that releases the binding energy to make light. But usually, excitons are very hard to maintain in a semiconductor.

"The excitonic properties in conventional semiconductors are only stable at extremely cold temperatures," Silva said. "But in HOIPs the excitonic properties are very stable at room temperature."

#### Ornate quasiparticle twirling:

Excitons get freed up from their atoms and move around the material. In addition, excitons in an HOIP can whirl around other excitons, forming quasiparticles called biexcitons. And there's more.

Excitons also spin around atoms in the material lattice. Much the way an electron and an electron hole create an exciton, this twirl of the exciton around an atomic nucleus gives rise to yet another quasiparticle called a polaron. All that action can result in excitons transitioning to polarons back. One can even speak of some excitons taking on a "polaronic" nuance.

Compounding all those dynamics is the fact that HOIPs are full of positively and negatively charged ions. The ornateness of these quantum dances has an overarching effect on the material itself.

#### Wave patterns resonate:

The uncommon participation of atoms of the material in these dances with electrons, excitons, biexcitons and polarons creates repetitive nanoscale indentations in the material that are observable as wave patterns and that shift and flux with the amount of energy added to the material.

# Lighting the World ONE LED AT A TIME

NICHIA's Optisolis™  
When perfection is the only option

## Optisolis™

- No UV emission
- Full spectrum close to natural sunlight
- Less disruptive circadian rhythm
- High color fidelity (Rf)
- Full color gamut (Rg)



757 Series



COB Series  
\*NEW\*

Request Your FREE Samples Now!  
[www.bit.ly/FLSNichiaSamples](http://www.bit.ly/FLSNichiaSamples)



[www.NICHIA.com](http://www.NICHIA.com)



[www.FutureLightingSolutions.com](http://www.FutureLightingSolutions.com)

Booth #1119

2019 LIGHTFAIR International  
Pennsylvania Convention Center • May 19-23, 2019  
Philadelphia, PA USA

Booth #1349

"In a ground state, these wave patterns would look a certain way, but with added energy, the excitons do things differently. That changes the wave patterns, and that's what we measure," Silva said. "The key observation in the study is that the wave pattern varies with different types of excitons (exciton, biexciton, polaronic/less polaronic)."

The indentations also grip the excitons, slowing their mobility through the material, and all these ornate dynamics may affect the quality of light emission.

#### Rubber band sandwich:

The material, a halide organic-inorganic perovskite, is a sandwich of two inorganic crystal lattice layers with some organic material in between them making HOIPs an organic-inorganic hybrid material. The quantum action happens in the crystal lattices.

The organic layer in between is like a sheet of rubber bands that makes the crystal lattices into a wobbly but stable dance floor. Also, HOIPs are put together with many non-covalent bonds, making the material soft.

Individual units of the crystal take a form called perovskite, which is a very even diamond shape, with a metal in the center and halogens such as chlorine or iodine at the points, thus "halide."

#### Acknowledgement:

The study was co-authored by Félix Thouin, David A. Valverde-Chávez, and Ilaria Bargigia, all of Georgia Tech; Claudio Quarti and David Beljonne of the Université de Mons in Belgium; Daniele Cortecchia and Annamaria Petrozza of the Istituto Italiano di Tecnologia. The research was funded by EU Horizon 2020 (project 705874); the Natural Sciences and Engineering Research Council of Canada; Fond Québécois pour la Recherche: Nature et Technologies; the National Science Foundation (grant 1838276); Interuniversity Attraction Pole program of the Belgian Federal Science Policy Office (PAI 6/27) and the Fonds de la Recherche Scientifique de Belgique (FNRS-F.R.S.). Beljonne is an F.R.S. director. Any findings, opinions, and conclusions are those of the authors and not necessarily of the funding agencies. ■

The original news is provided on the Georgia Tech website. The research was published in Nature Materials (doi.org/10.1038/s41563-018-0262-7)

## Zhaga Book 18 - Certification Program for a Smart Luminaire Interface

### Zhaga and DiiA Agree to a Joint Certification Program for a Smart Luminaire Interface

The Zhaga Consortium (Zhaga) and the Digital Illumination Interface Alliance (DiiA) are developing a joint certification program for interoperable luminaires and components, which enables intelligent, future-proof LED luminaires with IoT connectivity.



**Based on complementary specifications that define the smart luminaire interface, the joint DiiA-Zhaga certification program will support interoperability and new value creation for Smart Cities using future-proof LED luminaires with IoT connectivity**

The certification program will be based on complementary specifications from Zhaga and DiiA, which together define the smart luminaire interface. This interface simplifies the addition of communication/sensor nodes to LED luminaires with plug-and play interoperability. Initially the focus is on outdoor lighting, but indoor solutions will also be developed.

The joint certification program will include outdoor LED luminaires, as well as components such as drivers, sensors and communication nodes. A certification mark will clearly indicate interoperability.

"Our joint certification program will provide the entire value chain with confidence in multi-vendor product interoperability," commented Ruud van Bokhorst, General Manager of DiiA. "It will reduce complexity and add value for luminaire makers and commercial end-users, allowing the upgrading of the digital functions of smart luminaires."

The smart luminaire interface is based on the DALI protocol for intra-luminaire communication, including the recently

published DiiA specifications for integrated DALI power supplies, and data storage/retrieval for asset management, energy reporting and diagnostics. These specifications will be referred to in the upcoming Zhaga Book 18 ed. 2.0 that also defines the mechanical connectivity interface and conditions for interoperability.

Interoperability based on open standards and supported by a robust certification program has far-reaching implications, resulting in value creation and reduced complexity for outdoor lighting and Smart City projects.

As Dee Denteneer, Secretary General of the Zhaga Consortium, points out, "Cities require plug-and-play interoperability between outdoor luminaires and communication/sensor nodes, to efficiently enable and future-proof their Smart City applications. The collaboration with DiiA allows us to cover all aspects of this interface, and the joint certification program and marking will confirm plug-and-play interoperability to our customers."

### Zhaga Confirms Plan to Transfer Book 18 to IEC

The Zhaga Consortium has confirmed its plan to transfer Book 18 Ed. 2.0 to IEC, after the completion of the specification expected by mid-2019 and approval by the General Assembly. This Book describes a smart interface for outdoor luminaires and specifies power, communication and mechanical aspects. The decision is following the already ongoing transfers of Books 1,7,10,12 and 14.

During its most recent members' meeting, the Zhaga Consortium confirmed its plan to transfer Zhaga Book 18 Ed. 2.0 to IEC. This transfer follows existing practice in Zhaga to bring successful and well adopted specifications to the IEC. This way, Zhaga achieves a wider consensus, a larger audience and full harmonization with existing and accepted IEC standards and practices. The transfer of Book 18 Ed 2.0 follows the ongoing transfers by Zhaga to IEC of its LED module Books 1, 7, 10, 12, and 14, which all have been successfully adopted by the market.

Zhaga Book 18 2.0 describes a smart interface for outdoor luminaires and specifies power and communication aspects in addition to the mechanical aspects already covered in Book 18 Ed. 1.0. The book simplifies the addition of application modules



# Philips Advance Xitanium LED Drivers with ComfortFade

## 50W (XI050C140V054PST1)

### Features & Benefits

- ComfortFade Technology for Smooth On-to-Off and Off-to-On Transitions
- Dim to Off Capability
- SimpleSet NFC based Programming
- 1% Min Dim
- 0-10V Dimming
- CSA, ETL, and UL Class P
- 50k hour Lifetime<sup>1</sup>
- 5-yr limited warranty

### Applications

- Indoor Linear
  - Troffers
  - Suspended
  - Retrofit

75W, 40W, and 30W drivers will be introduced over a period of time into 2019

<sup>1</sup> Philips Advance Xitanium LED drivers are manufactured to engineering standards correlating to a designed and average life expectancy of 50,000 hours of operation at maximum rated case temperature. Minimum 90% survivals based on MTBF modeling.

For up to date warranty information please go to <http://www.usa.lighting.philips.com/support/support/warranty>



[www.FutureLightingSolutions.com](http://www.FutureLightingSolutions.com)

2019 LIGHTFAIR International

May 19-23, 2019

Philadelphia, PA USA

Pennsylvania Convention Center

Booth #1349



such as sensors and communication nodes to LED luminaires with plug-and-play interoperability. This interoperability will be of great benefit to the entire value chain. It reduces complexity and adds value for the luminaire maker, installer and possibly more importantly the specifier. Zhaga Book 18 Ed 2.0 will allow any certified module to operate with any certified luminaire.

"The Zhaga mission is all about interoperability", Zhaga SG Dee Denteneer comments, "and what we are aiming for with Book 18 is a "USB-like industry standard for lighting". A transfer to IEC of only the mechanical interface specified in Zhaga Book 18 Ed. 1.0 would fall short of our goals. Therefore, we will initiate the transfer only when Ed. 2.0 has been completed because this edition safeguards full interoperability."

Zhaga will initiate the transfer with highest priority after the completion of the specification and its approval by the General Assembly, expected by mid-2019.

#### Background:

By making it easy to add or upgrade sensors or communication nodes, the smart luminaire interface enables future-proof luminaires that can keep pace with rapid developments in digital networking and sensing technology. With a suitable wireless communication node, the luminaire is able to interact with an external lighting-control network, and to participate in the IoT.

The smart luminaire interface uses the mechanical form-factors specified in Zhaga Book 18 for the connector plug and socket, as well as the electrical pin assignment. Communication/sensing nodes and LED drivers are connected by means of an intra-luminaire DALI bus, enabling bi-directional communication using the well-established and standardized DALI protocol.

The LED driver is able to store and report operational and diagnostic data (DALI Parts 252 and 253), as well as information about the luminaire for inventory tracking and related purposes (DALI Part 251). Also, the power-supply requirements of the communication/sensor node, when connected to the Zhaga socket, are defined in the DiiA specifications for integrated bus power supplies (DALI Part 250) and auxiliary power supplies (AUX specification). ■

## Amazon to Join Zigbee Alliance Board of Directors

The Zigbee Alliance, an organization of hundreds of companies creating, maintaining, and delivering open, global standards for the Internet of Things (IoT), has announced that Amazon will join its Board of Directors. As IoT growth continues to accelerate, prominent companies in the tech industry are collaborating within the Zigbee Alliance to shape the direction of standards, ecosystems, and devices to offer users easy and enjoyable experiences they'll want to build upon within their homes and personal spaces. The decision by Amazon to join the Zigbee Alliance at the Board level is a strong message that the industry is focused on simplifying and adding convenience to the growing range of IoT devices available to customers.



#### The appointment with Amazon supports continued work to simplify and standardize IoT for customers using Zigbee wireless technologies

"Customers tell us they want smart home experiences that are simple to setup, easy to control, and add convenience to the tasks they do every day," said Christian Taubman, Director, Alexa Smart Home at Amazon. "Voice control with Alexa is helping remove the complexity of smart home, and there are even more ways we can help customers by ensuring their smart devices connect and work together seamlessly. We look forward to working with the Zigbee Alliance and its members to contribute to open standards for device interoperability that benefit all customers."

#### Smart Home Satisfaction:

Moving beyond its infancy, the smart home is taking hold and consumers are embracing IoT products as they continue to become easier to use. Manufacturers and standards organizations are bridging differences and breaking down barriers for the good of the entire industry. With voice services like Amazon Alexa and products such as the Amazon Echo family — which serves as the

'brain' or hub of choice in smart homes across the world — consumers can intuitively connect lights, locks, sensors, and more to broaden the conveniences around them.

"As an industry, we need to move quickly to help consumers add new devices effortlessly, and ensure they are getting a great experience in the Internet of Things," said Tobin Richardson, President and CEO, Zigbee Alliance. "We're proud to be attracting the best tech companies on the planet, and Amazon joins an impressive lineup of other industry leaders and innovators on the Board who work with the Zigbee Alliance's open standards and community to deliver real value in the IoT."

#### Hubs & Ecosystems Unite:

Finding a common vision and mature, interoperable solutions within the Zigbee Alliance family of technologies, leading service providers and device manufacturers - such as Amazon, Comcast, Huawei, IKEA, Legrand, Schneider Electric, Signify (formerly Philips Lighting), Somfy, and Samsung SmartThings - have chosen to design and introduce devices based on the Zigbee Alliance's wireless standards. In doing so, these companies offer consumers greater choice in building simpler, consistent, and reliable experiences. For instance, Amazon devices including the Echo Plus and new Echo Show feature a built-in smart home hub that easily connects to Zigbee-based light bulbs, door locks, sensors, and more. Now, customers can benefit from Frustration Free Setup and quickly connect new Zigbee products by simply saying "Alexa, discover my devices."

"Pairing Amazon's Alexa-based technology with the Zigbee Alliance's prominent wireless standards makes a lot of sense for not only manufacturers looking to partake in the smart home, smart building, and connected city categories but more importantly for the consumers that must embrace and champion connected technology for it to grow by contributing value to our everyday lives," said Mareca Hatler, Principal Analyst at ON World. "Our research projects Zigbee technology will ship in 85% of the 4.5 billion 802.15.4 units predicted to hit the market in 2023, and with Amazon as a Board contributor in the Alliance, it's clear the market-movers are really pulling together and operating on a global level to steer everyone forward." ■



# LUXEON V2

Best performance. Most usable light. Proven package.

LUXEON V2 is a Chip Scale Package (CSP) based high power domed LED optimized for directional applications to continue Lumileds leadership in this category. LUXEON V2 delivers high efficacy and robustness in a 3535 package with 3-stripe footprint designed to accelerate time to market by matching the radiation pattern of competitive products, while improving system costs through unparalleled performance (flux and efficacy) at higher drive currents.

- 450lm @ 150lm/W
- CSP 2mm<sup>2</sup> die technology delivers high efficacy at high drive current — provides design flexibility and supports high flux density
- Emission and source luminance distribution designed to match competition enabling drop-in compatibility and accelerates time to market
- 3535 ceramic package with 3-stripe footprint for ease of design

## Applications

- Architectural
- High Bay & Low Bay
- Outdoor
  - Stadium
  - Street and Area Lighting

To find out more on LUXEON V2, visit [FutureLightingSolutions.com](http://FutureLightingSolutions.com) or contact your local FLS representative.

## TECHNICAL REGULATORY COMPLIANCE UPDATE



Segment	Product	Standard (Certification)	Region	Technical Regulatory Compliance Information
Energy Labelling	Lighting products	Decision 4889/QD-BCT	Vietnam	According to the most recent decision No.: 4889/QD-BCT technical standards for the mandatory energy labelling of LED lighting products will apply from January 1, 2020. LED luminaires will have to meet several requirements regarding parameters like minimum life span, safety and energy performance. The relevant standards are listed in Article 2 of the decision
Law	Incandescent and halogen lamps	Law 27492	Argentina	The Senate and Chamber of Deputies published the new law 27492 which amends the already existing law 26.473/2008 about the import ban of residential incandescent lamps as of 31 December 2010. The new law extends the prohibition on the import and sale to all types and models of halogen lamps as of 31 December 2019.
Safety standard	Lighting products	IEC 62493:2015 EN 62493:2015	World & Europe	Assessment of lighting equipment related to human exposure to electromagnetic field. New version is still not listed in the official journal. Nevertheless all lighting products need consider the EMF phenomena and may apply this standard. The one where no test is needed can stop at clause 4.2.2 but still need to have a minimum test report stating that they are excluded from further testing and deem to comply with the requirement.
Safety standard	Lighting tracks	IEC 60570-1:2003 A1:2017 EN 60570-1:2003 A1:2018	World & Europe	Electrical supply track systems for luminaires. Major changes: <ul style="list-style-type: none"> <li>• Clause 1 and 7 extended scope to include also up to 60 Vdc systems</li> <li>• Correction of figure 3 of class I tracks</li> </ul>
Safety standard	LED modules	IEC 62031:2018 EN IEC 62031:201x ratified 2018-xx	World & Europe	LED modules for general lighting. Safety specifications. Main changes: <ul style="list-style-type: none"> <li>• Scope and wording in several clauses clarified</li> <li>• Marking of working voltage was modified</li> <li>• Requirements for other than integral terminals added</li> <li>• Annex B was deleted</li> <li>• Information for luminaire design was detailed</li> <li>• Abnormal temperature test was introduced</li> </ul>
Safety standard	Luminous signs	EN 50107-3:2018	Europe	Product standard covering luminous signs with discharge lamps and/or LED and/or EL light sources with a nominal voltage not exceeding 1000V, with the exclusion of general lighting, traffic- or emergency related purpose.
Energy Labelling	Energy related products - lamps	(EU)2017/1369	Europe	Since 1. January 2019 all light sources need to be registered incl. when delivered with a luminaire in the package. The database will go public visible to consumer and market surveillance in April 2019. Till June 2019 all light sources placed on the market since August 2017 need to be entered into the EPREL database.

**Disclaimer:** This information is research work of TÜV SÜD Product Service and is intended for general information purposes only. The content is publishable only after having the consent of TÜV SÜD Product Service. If it is published with any changes, the company is not liable for it. The information is subject to change and all rights for it are reserved by TÜV SÜD Product Service GmbH.

A free training can be arranged for a clear understanding of the upper stated standards.

For further information on the latest upgrades and testing standards and training, please contact [cps@tuv-sud.com](mailto:cps@tuv-sud.com)



# Light up the world!

From the USA to Europe, we certify your products under NRTL, ENEC, ENEC+, CCC, Zhaga, and other standards and also perform basic tests on your behalf. Rely on our service!



Contact our experts:  
[www.tuvsud.com/lighting](http://www.tuvsud.com/lighting)



Product Service

**Add value.  
Inspire trust.**



# Tech-Talks BREGENZ - Dr. Scott Wade, Technical & Certification Manager, DiiA



## Dr. Scott Wade

Dr. Scott Wade has been Technical & Certification Manager for DALI/DiiA since August 2013, and for around 14 years has been an industry expert member of the IEC 62386 standardisation team. Prior to DALI/DiiA, Dr. Wade was NPI Director for Electronics and Systems at Honeywell ED&S, and prior to that was at Helvar, most recently as R&D Manager for Lighting Controls. Dr. Wade holds a Ph.D. in Power Electronics and M.Eng. in Electrical and Electronic Engineering.

Dr. Scott Wade has been the Technical & Certification Manager for DALI/DiiA since 2013 and has been an industry expert member of the IEC62386 standardization team for about 14 years. He was invited to hold a lecture at the LpS 2018 about the founding of DiiA for the purpose of taking over the DALI trademark from ZVEI and discussed measures that were taken to further develop the standard and its certification process and make the DALI concept future proof with DALI-2.

**LED professional:** Thank you for taking the time to be here. I think it might be interesting for our readers if you could give us some background information on DiiA (Digital Illumination Interface Alliance).

**Scott Wade:** Yes, of course. As you might already know, DiiA was founded about two years ago and took over the DALI trademarks from the ZVEI, the previous organization. The number of members has grown very quickly currently, we have more than one hundred and sixty members, worldwide. So it is a global organization. The main aim of the organization is to promote the use of lighting-control technology, based on the latest version of IEC 62386, which is very commonly known as the DALI standard.

**LED professional:** ZVEI also had members. Did you take those members over or did you have to recruit new ones?

**Scott Wade:** ZVEI stopped the DALI organization known as DALI AG and the vast majority of members have already transferred

across to DiiA. DiiA member companies are almost all in the lighting control industry. Original members from years ago would be mostly control-gear manufacturers. But now we have many control-device manufacturers as well. Control gear includes products such as LED drivers, ballasts and electronic transformers, while control devices are products such as sensors, routers, and gateways. So we have a good mixture of manufacturers covering all those types of products now.

**LED professional:** What about all the responsibilities DiiA took over from ZVEI?

**Scott Wade:** Initially, the DALI version-1 tests were taken over and the use of the DALI version 1 trademark was allowed by our DiiA members. However, in August 2017 we launched the DALI 2 certification program. We developed a new set of tests for DALI-2. Initially, many LED drivers were certified for DALI-2 and then we had the first DALI-2 application controllers. Those first ones were single-master application controllers you can

only have one of those in a system. However, in August 2018 we extended the certification program to include multi-master application controllers for the first time. Application controllers are the decision makers, and you must have at least one in a system. They send the commands to the lights, through the control gear, to tell them what level, what scene or what fade time to use. In DALI version 1, these were not part of the standard so they were all proprietary, but now they are part of the standard and they are part of the DALI-2 certification process, as well.

**LED professional:** If we talk about differences between the systems it might be interesting to know how a DALI version-1 system and a DALI-2 system work.

**Scott Wade:** The DALI version 1 standard was only for control gear. Examples include LED drivers, fluorescent ballasts, electronic transformers for halogen or HID lamps, and color control gear. The limitation was that there was no standard for the control

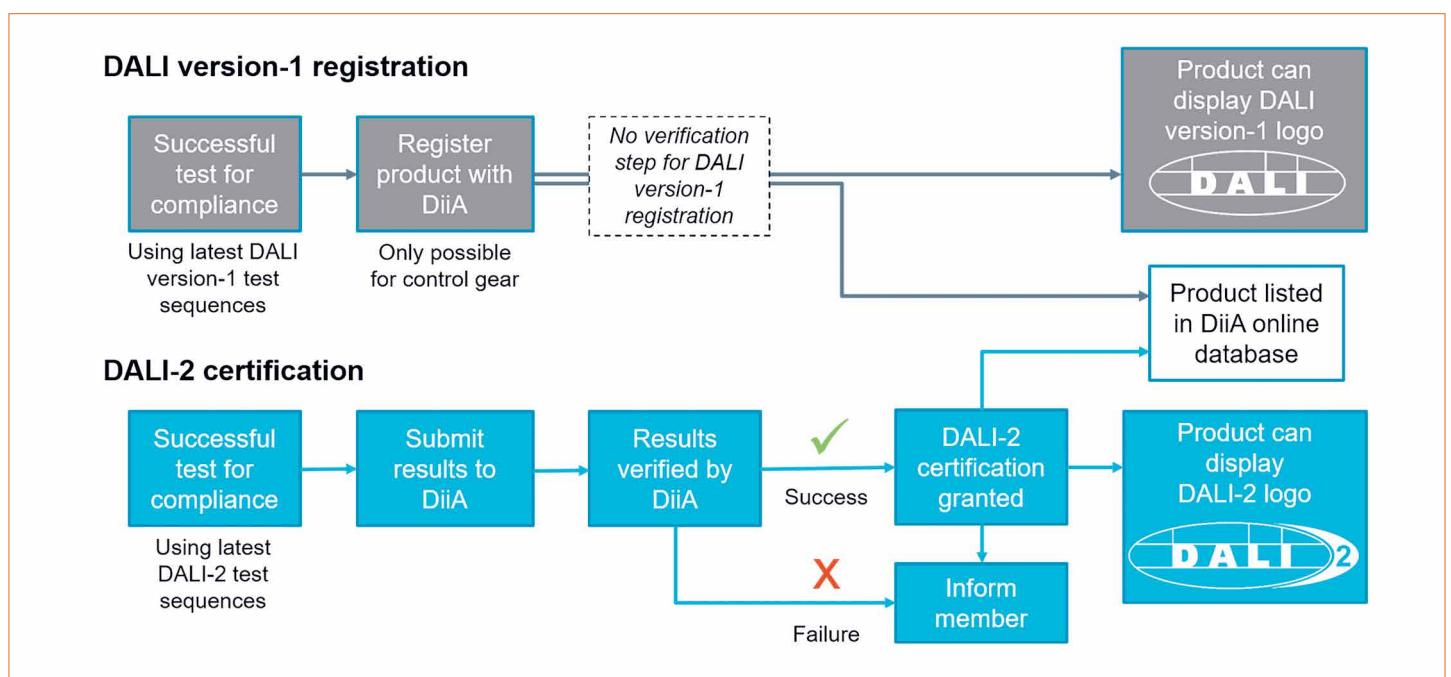

DALI-2 certification includes a verification step to confirm that the test results provided by the DiiA member are fully compliant with the DALI-2 test specifications



Truly an expert talk:  
Dr. Scott Wade and  
Dr. Guenther Sejkora

devices. The devices that make the decisions, as well as the sensors, the push buttons, the sliders all of these types of control devices were not in the DALI version 1 standard. DALI-2 made two big steps: The first one was a big increase in interoperability for control gear. We removed ambiguities from the standard, and we increased the amount of tests. As an example, in DALI version 1, an LED driver takes around one day to test, but for DALI-2 certification, an LED driver takes around three days to test it fully. Most of the testing is automated. The end result of the improvement in the standard and the greater number of in-depth tests is a much higher level of interoperability in DALI-2. The second big step is that control devices are included. This means that the new standard includes all control gear, the control devices, and the bus power supplies. DiiA provides tests for all of these, and includes them in the DALI-2 certification program.

**LED professional:** Is the bus system different?

**Scott Wade:** The bus itself is the same two-wire bus, carrying power and data. The signals on the bus are better specified in DALI-2 so there's less ambiguity. But actually, DALI-2 is backwards compatible with DALI version 1. You can mix products, you can have DALI version 1 control gear

and DALI-2 control gear in the same system (on the same bus), and they will work together. No problems are expected. You can even replace DALI version 1 control gear with DALI-2 control gear.

**LED professional:** So the DALI-2 controller is not defined in DALI version 1, but a DALI-2 controller would work together with an old system?

**Scott Wade:** That's correct, yes. The DALI-2 control devices will be able to work with the DALI version 1 control gear, because the backwards compatibility has been maintained we've taken very little out of the DALI version 1 standard. There was only one feature we removed that wasn't used, but we asked all of our members first. In DALI-2 we have made the standard much clearer and also added more features. For example: the fade time. In DALI version 1 there is a standard fade time from 0.7 seconds up to 90 seconds. All control gear has to follow those fade times. But also in DALI version 1, LED drivers had a fast fade time, much faster than 0.7 seconds. However, that was only available to LED drivers. Now, in DALI-2 we recognized that all lamp types could make use of this. We have added an extended fade time for DALI 2 control gear, allowing fades from 0.1 seconds to 16 minutes to be recalled with a single command. However,

the original fade times from 0.7 seconds up to 90 seconds still exist in DALI-2. So in that way we have maintained backwards compatibility.

**LED professional:** If you have an old system one that isn't standardized and you replace one single control gear, would it work or might there be a problem with the protocol of the controller?

**Scott Wade:** Due to the backwards compatibility, it will work. No problems are expected. In fact, you're likely to have fewer problems replacing your DALI version 1 control gear with DALI-2 control gear. The reason is that we've improved interoperability of the products by making the standard clearer and the tests more detailed. So that will most certainly reduce the chance of problems. But you're right that old controller will work with both the DALI version 1 and the DALI-2 control gear. Of course it's not likely to make use of the new features that we brought into DALI-2.

**LED professional:** But I think it's also important to be able to replace a control device in an old system if it breaks.

**Scott Wade:** That's exactly right. Now we can't absolutely guarantee it, but the tests and the certification that we do with the DALI-2 products help to ensure interoperability.

**LED professional:** What new possibilities are offered in the application by the new system?

**Scott Wade:** For the control gear, we have added features such as the extended fade time. So that opens up new opportunities for applications going to faster and slower fade times. We have also just published five new specifications, which are available on our website. These specifications are especially useful for outdoor luminaires, but also for indoor use. We've also started collaborating with the Zhaga organization because of their expertise in the connectors and the sockets and our expertise in the protocol and the power supplies. Although those are not strictly new applications, there are new features to help in those applications and also to bring more benefits for IoT applications. For example, one of the new specifications is luminaire data which is very useful for asset tracking. So now, using this new specification, you can query lots of information about the luminaire and the lamp: for example, its color temperature or the nominal light output in lumens. There are also new specifications for energy and power metering as well as

maintenance and diagnostics. So these are all new specifications opening up new applications or improving existing applications.

**LED professional:** Correct me if I'm wrong, but I heard that a major difference between DALI version 1 and DALI-2 is that before they didn't allow active sensors on the bus. The controller had to send a request and the sensor would give an answer.

**Scott Wade:** This is a fairly common misunderstanding about DALI version 1. There was no standardization of the sensors or the controllers in version 1. Manufacturers could choose how to implement those: whether to allow only one in a system we call it a single master or to allow more than one a multi master system. Both are actually allowed in DALI version 1, there just isn't a standard for it. And both do exist. DALI-2 also allows both ways, but now it's standardized. Part 103 of the standard so that's IEC 62386-103 describes both the single master and multi-master requirements. Application controllers can be either single-masters or multi-masters. The sensors, the push buttons, the rotary controls, the slider controls these are input devices and must be multi-masters,

automatically allowing more than one of them to be used on the DALI bus at the same time. So if you're designing a system where you want to have lots of control devices, you can have multiple input devices as well as multiple application controllers, if you wish. But that depends on your application. It's quite common to have one application controller, the decision maker the brain, making the decisions for all of the lighting in that system. But you can also have distributed intelligence. Both possibilities are still there. The difference is that now we have standardized it.

**LED professional:** Is there also a difference between DALI version 1 and DALI-2 when it comes to being able to control multiple channels?

**Scott Wade:** Yes. In DALI version 1, the control gear could only have one DALI address we call it the short address, and you could have up to sixty-four of those on one DALI bus. Now, you can have multiple short addresses within one product. We call those logical units. As an example, you could have an LED driver with three logical units. Each logical unit needs one DALI

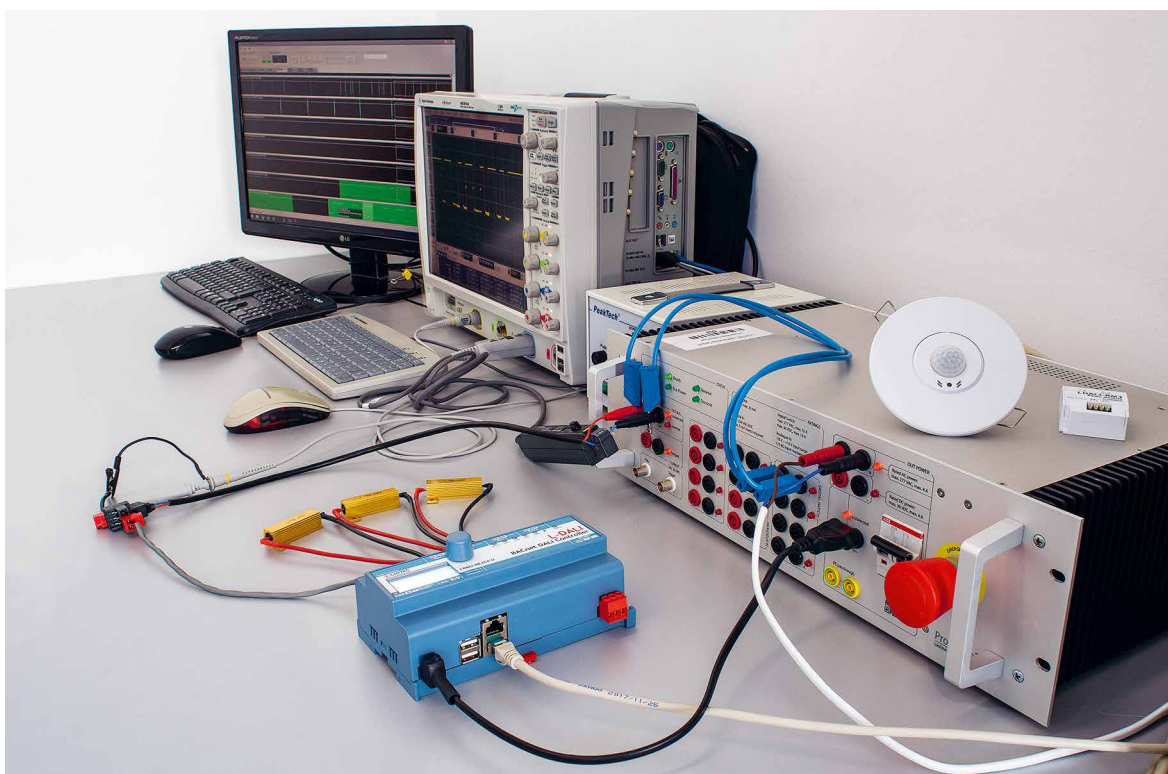

Typical set-up for DALI-2 testing, showing a DALI-2 application controller (center front) and a ProbitLab2 tester from Lichtvision Engineering (right) (Image credits: LOYTEC electronics)

address and might be controlling one lamp. Each of those logical units controls its lamp independently of the other two logical units in that control gear. With DALI 2 you can now design, test and certify those products that have multiple DALI short addresses.

**LED professional:** Is the number of short addresses still restricted to sixty-four?

**Scott Wade:** No, this has also changed. There are still sixty-four short addresses for control gear, but now we have added a further sixty-four addresses for the control devices. So there are sixty-four control-gear addresses and sixty-four control-device addresses that can be on the DALI bus at the same time.

We also have sixteen groups for control gear and thirty-two groups for control devices, as well as a broadcast address to which all control gear or control devices will respond. There's also one new addressing mode known as broadcast unaddressed, which can help to speed up the commissioning process.

Further grouping is possible at what we call the instance level.

A push-button panel, for example, might have eight push buttons on the same product, and each of those buttons is one instance. They all share the same short address, but each of them has its own instance number.

**LED professional:** I think that point is interesting because, with the current trend of trying to connect more and more sensors, more and more devices, it looks like the requirements might be beyond sixty-four plus sixty-four.

**Scott Wade:** That's right. Now, this complexity in addressing wouldn't be seen by the end users of a system. Even the commissioning engineers depend on the software developed by the manufacturer. In my opinion, good commissioning software will hide all the complexity of groups and addresses. It's possible to show the system in a more user-friendly way.

**LED professional:** I think that with this DALI-2 standard, the DALI version 1 is more or less obsolete or will certification for DALI version 1 last for a while?

**Scott Wade:** For DALI version 1 we talk about registration,

while certification is only for DALI-2. There is one big difference: In DALI-2 certification, the members must send us the test results from the product and we verify that they are genuine and all tests have passed. In DALI version 1, that's not done. The companies are self-testing or possibly using a test house. They can then apply the DALI version 1 trademark logo to the device and they register it on our web-site.

DALI version 1 is not obsolete, yet. I estimate that most manufacturers are now developing DALI-2 control gear instead of DALI version 1. But some parts of the standard are still being transferred to DALI-2. For example, color control is not updated to DALI-2 yet that's something we're working on now. So a color control gear is still developed according to DALI version 1.

**LED professional:** On the subject of testing, there are the standard test procedures that have to be fulfilled, but is there also standard test equipment that the manufacturer can buy?

**Scott Wade:** Yes, they can. There are two types of test equipment. There's the ProbitLab

The DALI-2 mark may only be used if the certification test results are verified by DiiA and compliance to the testing requirements is 100% guaranteed



and the ProbitLab2. The ProbitLab is the older one, and is only for control-gear testing. ProbitLab2 can test all types of products. DiiA doesn't sell the test equipment; it comes from our technology supplier, Lichtvision Engineering. DiiA members that are self-testing are provided with the test-sequence software from us. It's part of the membership benefits to provide the latest version of the test sequences as well as updates.

The alternative is to send products to a test house. We list DiiA-accredited test houses on our website. Once the product has been tested, the members send us the results through their account on the DiiA website. Once the information is verified, certification is granted. As soon as certification has been granted, the product is automatically listed as DALI-2 certified. If it's listed, it means the member can apply the DALI-2 trademark to the product.

**LED professional:** DALI is a well-established protocol. But aren't there limitations in respect to system size that might restrict it for a lot of applications?

**Scott Wade:** This has never been a restriction of DALI. If you look, even

going back to the early 2000's, there have been lighting-control systems for whole buildings or even across multiple buildings. DALI is a subnet within the building. So you would have multiple subnets within one building joined into devices called routers or hubs or gateways. So DALI is a very good fit to a whole-building, lighting-control system. The backbone of that system could be another protocol such as Ethernet or a WiFi-based protocol.

**LED professional:** When you get to that point it is often argued that you would need another node a router or a gateway which is another critical point for hacking and some failures.

**Scott Wade:** Actually, in my view, this can make the system more robust, because DALI is a subnet. If, for example, a fault occurs within a gateway, each DALI subnet can continue to operate independently. You don't have to have a system that stops working just because one gateway stops working. The sensors and the push buttons still operate within that room.

On the security side, that's out of the scope of DALI physical access to the bus or devices is necessary to make changes to the system.

We recognize that there are other protocols that have solved the security problems. So it makes sense to use one of those protocols as the backbone, joining the DALI subnets together into a larger system.

**LED professional:** DALI is a 2-wire bus system. Then there is the wireless method. It seems that the mainstream is moving away from anything that is wired. How do you see this situation?

**Scott Wade:** If you listen to some in the industry, they believe that commercial lighting will move totally across to wireless. Personally, I don't see that happening in the near future. The enormous advantage that a wired system, such as DALI, has is that when you install it, it works. With a wireless system, you don't know if it's going to work. You don't know if there's going to be interference or if the signal strength is going to be an issue. So wireless is a bit of a gamble going into a building and installing it throughout the building. Whereas, with a wired bus, such as DALI, you wire the components to it and you don't have an interference problem, or a distance problem, or a latency problem.

The number of DALI-2 certified components is continuously increasing



With DiiA taking over the responsibility for DALI certification, DALI-2 has been established, further improving compatibility between DALI components

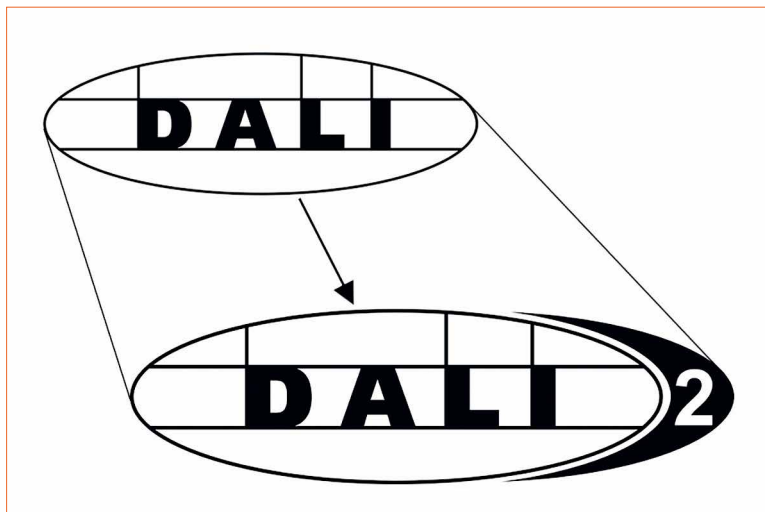

There are applications where it makes sense for parts of a building to be wirelessly connected. This is true for certain building types, for example an old cathedral where you don't want to put new wiring in. There it might make sense to have some of the controls connected wirelessly. But as for the whole building I don't see it at the moment.

**LED professional:** What about the cost difference between a wired system and a wireless system?

**Scott Wade:** That's a good question. I don't think anyone has good cost data for a wireless system, so far. This might be due to problems you have in installation, such as extra time to trouble-shoot the wireless problems and possibly add extra products to get the hopping distance that's required in a wireless system. Another issue for wireless in a lighting system is luminaires tend to be made of metal. So it can be quite difficult to get an RF signal out of a luminaire and to the next luminaire. That's where the wired bus of DALI has a great advantage. You wire the luminaires together and you know it's going to work.

Another big advantage of DALI over wireless or even other wired protocols is that DALI has power and data on the same two wires. It's not sufficient power to drive your luminaire, but it is sufficient to power sensors or push-button controls for example.

**LED professional:** Is it correct when I say that DALI is very common in indoor lighting but not so much in outdoor lighting or street lighting?

**Scott Wade:** That depends on the region you're looking at. I believe there are hundreds of thousands of streetlights in the U.S. now using DALI and these numbers are increasing rapidly. We have also just released five new specifications to our members, where the main driving factor was outdoor lighting. One of the main reasons for using DALI in outdoor lighting is that it's the only standard that specifies the light output dimming curve. In DALI, if you ask for a 50% level, the light output has to be 50% within a certain allowed tolerance.

The streetlight manufacturers see this as a huge benefit because they can choose their control gear, their LED drivers, from any manufacturer, mix them in the system, and when they ask for 50%, all of those streetlights, even though they have control gear from different manufacturers, all go to the same light output level.

Another strong reason is that DALI provides two-way communication allowing feedback from the luminaires this is very useful for maintenance, asset tracking and power monitoring.

**LED professional:** Are there any limitations in the length of the bus between streetlights, for example?

**Scott Wade:** In outdoor lighting applications, DALI isn't normally used to connect every pole. Instead, there is a very small DALI system within each streetlight. It might be just the control gear and a sensor, for example. Or it might even have a wireless-communication device. These products make up one complete DALI system. The new standards that we have developed allow lots of the luminaire data to be provided over the DALI bus and then that can be communicated wirelessly through other protocols.

**LED professional:** So the communication is mainly wireless and the control is DALI.

**Scott Wade:** Yes, that's right. The control within the streetlight is DALI control. Within the city it's likely to be a long-range wireless protocol.

**LED professional:** Are you intending to extend DALI beyond DALI-2?

**Scott Wade:** There are a number of extensions that are currently in progress. The five new specifications were developed by the DiiA. But we also plan to give those specifications to the IEC 62386 working group to make them international standards alongside the rest of the DALI protocol. The IEC working group, itself, is also working on new drafts. For example, a draft on firmware update is in progress, to allow the firmware the software within all devices to be upgraded in the field. So without having to remove products, you will be able to upgrade directly, over the bus. There are also new drafts for color control and other features in progress. There are no plans to change the name; these are all additions for DALI-2. As new parts of the standard are developed, the DALI-2 certification process will be extended to allow these new devices to be certified.

**LED professional:** I think the firmware update is a very important feature and it would be interesting to know when we can expect the standardization of the firmware update.



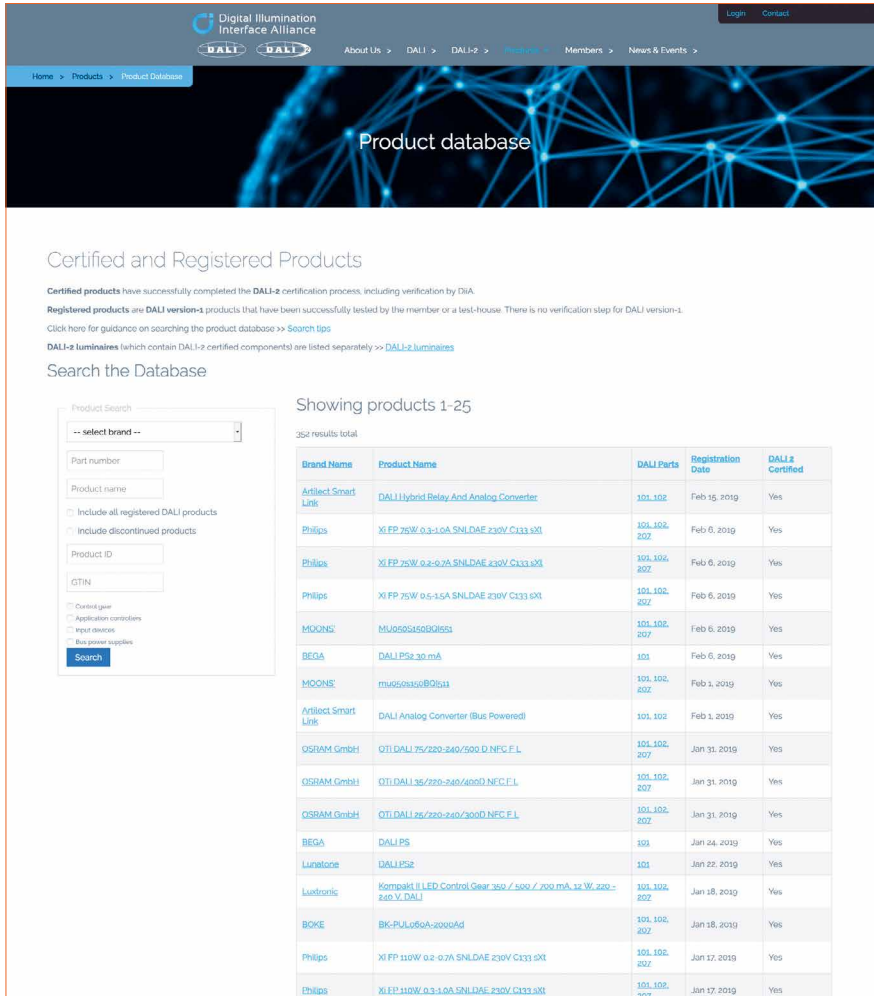

Product database

Certified and Registered Products

Certified products have successfully completed the DALI-2 certification process, including verification by DiiA.  
Registered products are DALI version-1 products that have been successfully tested by the member or a test-house. There is no verification step for DALI version-1.  
Click here for guidance on searching the product database >> [Search tips](#)  
DALI-2 luminaires (which contain DALI-2 certified components) are listed separately >> [DALI-2 luminaires](#)

Search the Database

Showing products 1-25

354 results total

Brand Name	Product Name	DALI Parts	Registration Date	DALI 2 Certified
Artilect Smart Link	DALI Hybrid Relay And Analog Converter	101_102	Feb 15, 2019	Yes
Philips	XI FP 75W 0.3-1.0A SNLDAE 230V C133 30I	101_102_207	Feb 6, 2019	Yes
Philips	XI FP 75W 0.2-0.7A SNLDAE 230V C133 30I	101_102_207	Feb 6, 2019	Yes
Philips	XI FP 75W 0.5-1.5A SNLDAE 230V C133 30I	101_102_207	Feb 6, 2019	Yes
MOONS	MU050S45GB0551	101_102_207	Feb 6, 2019	Yes
BEGA	DALI PS2 30 mA	101	Feb 6, 2019	Yes
MOONS	mu050s45gb0551	101_102_207	Feb 1, 2019	Yes
Artilect Smart Link	DALI Analog Converter (Bus Powered)	101_102	Feb 1, 2019	Yes
OSRAM GmbH	OTI DALI 75/220-240/500 D NFC F L	101_102_207	Jan 31, 2019	Yes
OSRAM GmbH	OTI DALI 30/220-240/600D NFC F L	101_102_207	Jan 31, 2019	Yes
OSRAM GmbH	OTI DALI 20/220-240/300D NFC F L	101_102_207	Jan 31, 2019	Yes
BEGA	DALI PS	101	Jan 24, 2019	Yes
Lumatec	DALI PS2	101	Jan 23, 2019	Yes
Ludronic	Kompakt II LED Control Gear 350 / 500 / 700 mA, 12 W, 220-240 V DALI	101_102_207	Jan 18, 2019	Yes
BOKE	BK-PUL050A-2000Pd	101_102_207	Jan 18, 2019	Yes
Philips	XI FP 110W 0.2-0.7A SNLDAE 230V C133 30I	101_102_207	Jan 17, 2019	Yes
Philips	XI FP 110W 0.3-1.0A SNLDAE 230V C133 30I	101_102_207	Jan 17, 2019	Yes

Any product that proved DALI-2 compliance in the certification process can be found on DiiA's products website with its extensive and user-friendly filter options

**Scott Wade:** I expect the publication of that standard will be sometime in 2019 but the date isn't set yet. The second draft was made in the middle of October 2018, so we have a new technical draft to review and discuss and update, if necessary.

**LED professional:** Do the new features have to be supported by DALI-2?

**Scott Wade:** New features such as firmware upgrade are optional, but if

included, then successful testing is necessary to achieve DALI 2 certification. The manufacturers have the choice of whether or not to implement them. I expect the market will decide which way they should go.

**LED professional:** Thank you so much for this really interesting interview.

**Scott Wade:** Thank you. ■

Announcing a new event  
from DiiA and Luger  
Research



DALI Summit  
2019

September 25, 2019

Co-located with  
LpS and TiL in  
Bregenz, Austria

Find out more:  
[www.dalisummit.org](http://www.dalisummit.org)

 Digital Illumination  
Interface Alliance

# Semi-Empirical Characterization of Freeform Microlens Arrays

Microlens arrays (MLA) have been used for imaging and non-imaging applications for a long time as cost-effective solutions. Non-symmetrical beam shapes require more advanced non-symmetrical freeform microlens arrays (FMLA). The required FMLA molding tools convey a high cost and an iteration process is required for the final design. Oscar Fernández, Tamara Aderneuer, Rolando Ferrini from the Centre Suisse d'Electronique et de Microtechnique, CSEM, and Julien Duchene from ANSYS proposed a method to overcome these limitations based on 3D surface sampling, computer generation of a ray-traceable model and ray-tracing performance simulation to demonstrate feasibility for several commercially available freeform asymmetric thin-film diffusers.

The practical advantages of microlens arrays, MLAs, have been widely exploited in diverse applications such as illumination, imaging, optical communication and security/anti-counterfeiting. On the other hand, the advances in computing and ultra-precision micro-machining achieved in the last years have enabled the design and manufacturing of the so-called freeform optical components. Such components, with no restrictions in rotational or translational symmetry, represent a fundamental shift and a powerful tool for optical designers and engineers to boost device miniaturization and performance, create new functionalities and reduce manufacturing costs.

Not surprisingly, freeform microlens arrays, FMLAs, are starting to attract attention both for imaging and non-imaging applications. However, the benefits enabled by the additional design freedom are accompanied by new challenges; being the lack of characterization methods a central one which, if not solved,

will hinder progress and innovation in this tremendously promising technology.

In an attempt to bridge this gap, a characterization method based on the experimentally measured surface micro-relief and subsequent creation of a ray-traceable CAD model has been developed. The optical performance of the created solid is accurately predicted using ANSYS SPEOS®, an optical modelling software package developed by ANSYS, Inc. The built-in features of ANSYS SPEOS enabled simulations under different conditions without confronting the physical limitations encountered in real characterization setups.

The results presented here exemplify the advantages of the proposed method and highlight the need for further research in this topic.

## Introduction

Microlens arrays, MLAs, defined as collections of microscopic lenses regularly arranged in a 1 or 2-dimensional pattern on a supporting substrate [1], offer several advantages when compared to macroscopic, single optical components, including miniaturization and manufacturing/ packaging cost reduction [2]. Additionally, the use of MLAs enabled opto-electronic devices with functionalities unreachable otherwise [3] such as integral photography, erect one-to-one imaging systems for photocopying and lithographic systems [4, 5], array generation for e.g. Shack-Hartmann wavefront sensors [6], etc.

Their microscopic surface relief enable microlens arrays, MLAs, to cover large areas with moderate volumes/weights, have a lower environmental footprint and retain substrate's flexibility, hence allowing replication over large areas using roll-based, cost-effective processes. Consequently, MLAs are commercially exploited today for, e.g. display brightness enhancement [7, 8], light extraction in LED [9] and OLED [10] lighting panels, beam homogenizers in

LCD projectors [11], glare-free LED panels [12, 13] (Figure 1), intelligent windows [14, 15] and world-record concentration photovoltaics [16].

Moreover, MLAs are widely used to couple light into arrays of other optical components such as VCSELs [17], CCD [18, 19] and LCD [20 - p.234] pixels and optical fibers for optical interconnections [4, 21]. Other advantages of MLAs include low heat production and mechanical inertia, high resistance to vibrations [22]. Finally, their invisibility to the naked eye make them very appropriate for security [23-25] and packaging [26] applications.

Remarkably, many applications require non-symmetrical light outputs. For example, commonly used image sensors are rectangular. Also, uniform illumination over rectangular targets (e.g. office tables, roads, and supermarket racks) is also a common goal in artificial lighting. In these cases, freeform optical surfaces, designed with no symmetry constraints, offer more efficient light utilization [27-29].

Furthermore, appropriately designed freeform components have higher ability to control Seidel aberrations independently, thus increasing the resolution, field of view and f-number coverage of imaging devices [30]. Finally, single freeform FMLAs can replace several MLAs hence reducing manufacturing and integration costs [31-36].

Freeform microlens arrays, FMLAs, which combine the design freedom of freeforms with the microscopic nature of micro-optics, are currently exploited in commercial applications such as laser beam-shapers and homogenizers [37] and asymmetric light diffusers [12]. On the other hand, FMLAs have enabled the design of compact monolithic imaging systems with high resolution and signal-to-noise, minimum off-axis aberrations, high signal-to-noise and large field of view [38-41]. 3D light-field displays and cameras [42-45] and see-through head-mounted glasses [46].

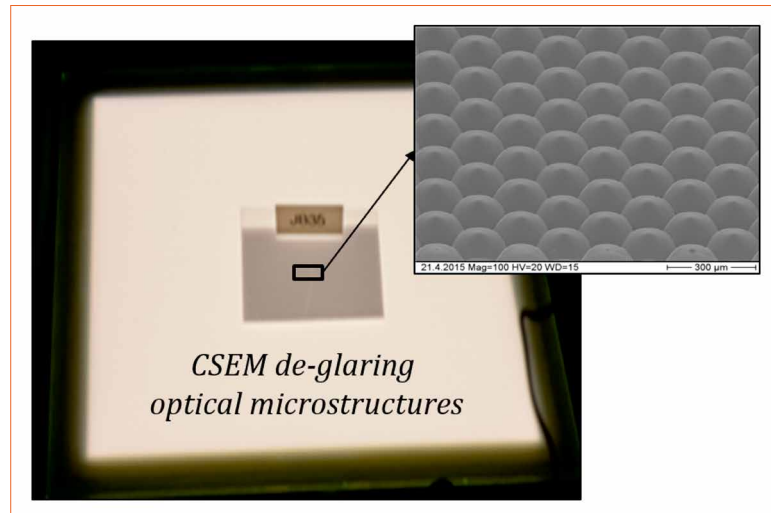

**Figure 1:** De-glaring thin-film solutions based on optical microstructures (developed at CSEM). The picture, taken at around 45° off-axis, shows a square piece of the de-glaring foil on top of a commercial OLED lighting device

### The Proposed Method

As a flip side, the use of freeform optics conveys specific challenges in terms of design, manufacturing and characterization [2]. The latter aspect, which has received much less attention, is fundamental for the success of FMLA technology and is the focus of this work.

A common approach to characterize MLAs is to measure the surface profile using, e.g., an optical profilometer and compare the results with the prescribed design target. MLAs are usually characterized by few parameters - residual layer, sag, pitch and fill factor and the impact of observed form error on the optical performance can be easily estimated. However, freeform surfaces are described by a much larger parameter space and oftentimes by non-parametric sets of points [37]. As a result, quantifying the form error and the resulting performance degradation is noticeably more complex.

On the other hand, FMLA tools are costly to manufacture and very small samples are typically produced (and subsequently steeped-and-repeated to produce the final large-area masters). Small samples are, however, difficult to handle and their characterization is prone to large experimental errors due to equipment and alignment limitations.

Both issues can be circumvented using a semi-empirical approach, which comprised two main steps. Firstly, the surface profile was recorded over a surface large enough to contain a significant number of microstructures (typically few mm<sup>2</sup>) and used to build ray-traceable CAD solid. Unfortunately, the whole process necessitated several intermediate format conversions (Figure 2) using different CAD software packages. The data provided by the profilometer had first to be transformed to a standard (.xyz) point-cloud format using an in-house model-based development software and thereafter converted into a Non-Uniform Rational B-spline (NURBS) surface, exported as .IGS format using ...

- RESURF point-cloud-to-NURBS fitting software and finally [i]
- imported into SolidWorks where it was [ii]
- extruded to the desired thickness and knitted to render solid properties to the model [iii].

In a second step, the optical performance of the built model was imported into a ray-tracing simulation tool and its performance simulated under preset conditions. ANSYS SPEOS [iv] is fully embedded into SolidWorks and is an excellent tool for our purpose. In addition, it offers a plethora of built-in features (in addition to those built-in within the SolidWorks environment) including, for example,

**Figure 2:** Schematic view of the process chain used in the creation of a ray-traceable CAD model from the measured surface profile

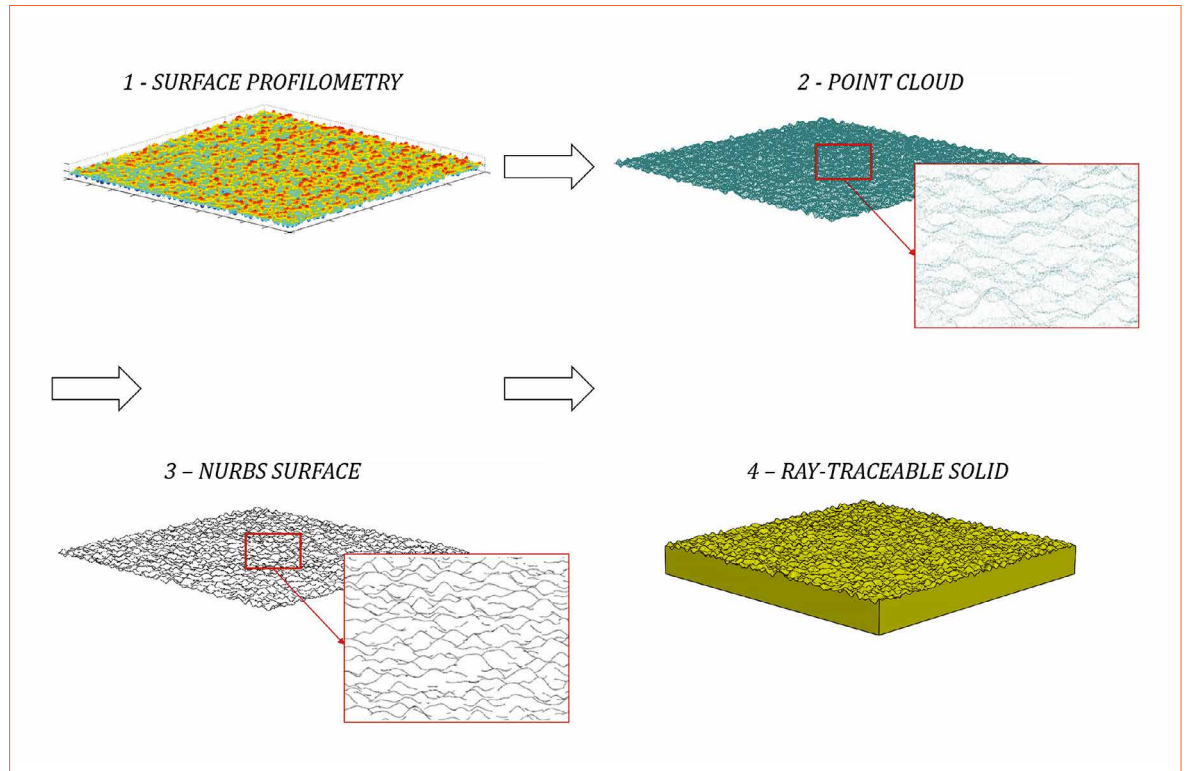

**Figure 3:** Optical set-up created in ANSYS SPEOS for the simulation of a CAD model illuminated by a collimated, monochromatic green light source. The resulting intensity and irradiance distributions produced by the solid are measured by the polar EULUMDAT and planar IRRADIANCE detectors respectively

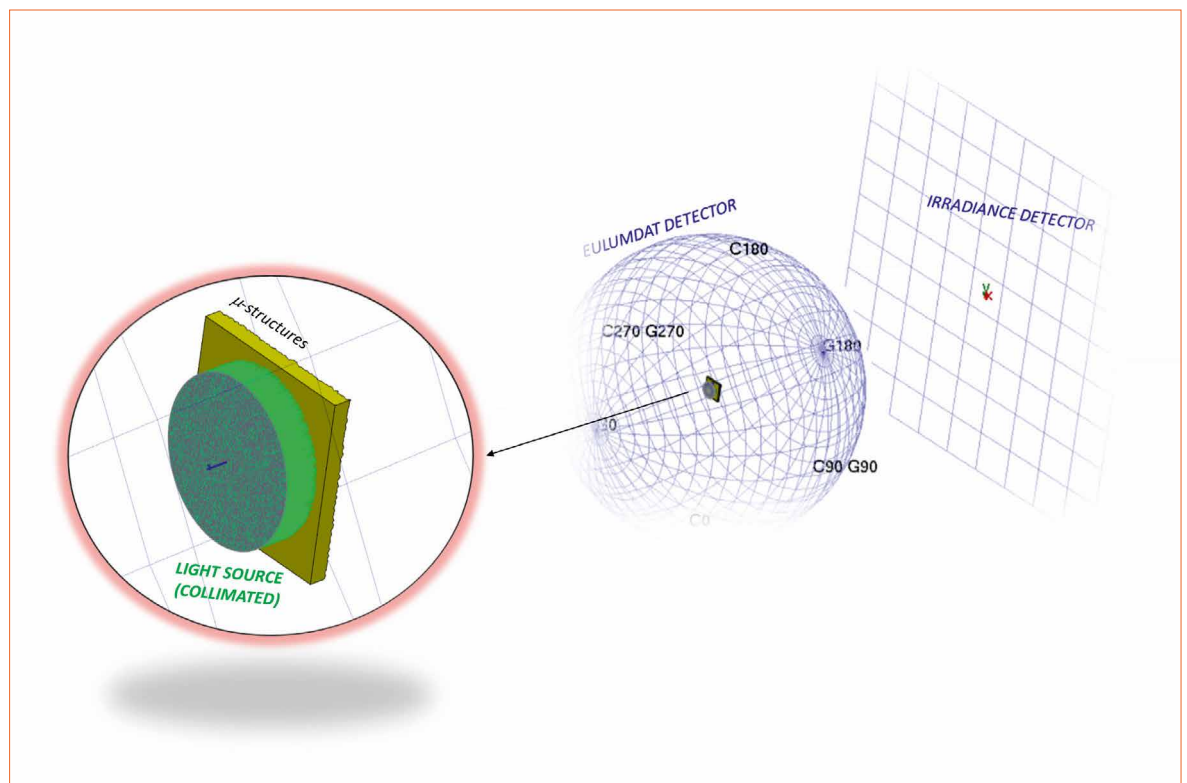

an extensive library of experimentally characterized light sources and materials, a wide range of detectors, and several data analysis packages (Figure 3).

## Results

We applied the method to characterize FMLA-based thin-film solutions.

The characterized FMLA-based thin-film solutions:

- Polyscale light defining film[v]
- RPC Photonics ED-S50 engineered diffuser [vi]
- BrightView E1060 asymmetric diffuser [vii]
- BrightView glare control diffuser G-GC90 [viii]

In the first 3 cases the CAD models were exposed to a highly collimated illumination and the irradiance recorded by a planar detector located at 100 mm from the sample (Figure 3). As a reality check the real samples were illuminated using a green laser and the illuminated target photographed. The results shown in figures 4 & 5 (left) clearly

# Starring CAS 140D!



## Sets the standard for LED/SSL and display measurements:

- ▲ High-end array spectroradiometer with excellent stray light suppressing design
- ▲ Superior measuring sensitivity, precision and dynamic range
- ▲ Proven lab and production software: SpecWin Pro/Light, DLL and LabView
- ▲ For enhanced goniophotometric analysis of all SSL light sources

Goniophotometer  
LGS 650 for  
probes up to  
1.3 m diameter



**We bring quality to light.**

**Figure 4a&b:** Polyscale defining film (a) and RCP Photonics ED-S50 (b) - CAD models and SEM pictures (left) and simulated and experimental irradiance distributions under laser illumination (right)

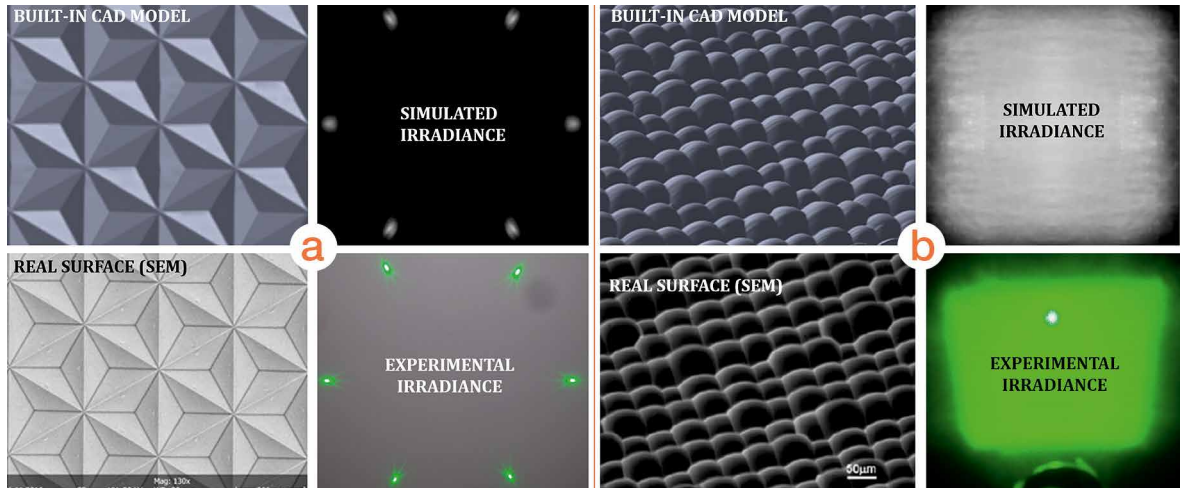

**Figure 5:** CAD models and SEM picture and predicted versus observed performance (left) of a BrightView E1060 asymmetric diffuser. BrightView G-CG90 de-glaring foil (right). Predicted and measured luminous intensity of a de-glared Phillips LF300 OLED (bottom-right)

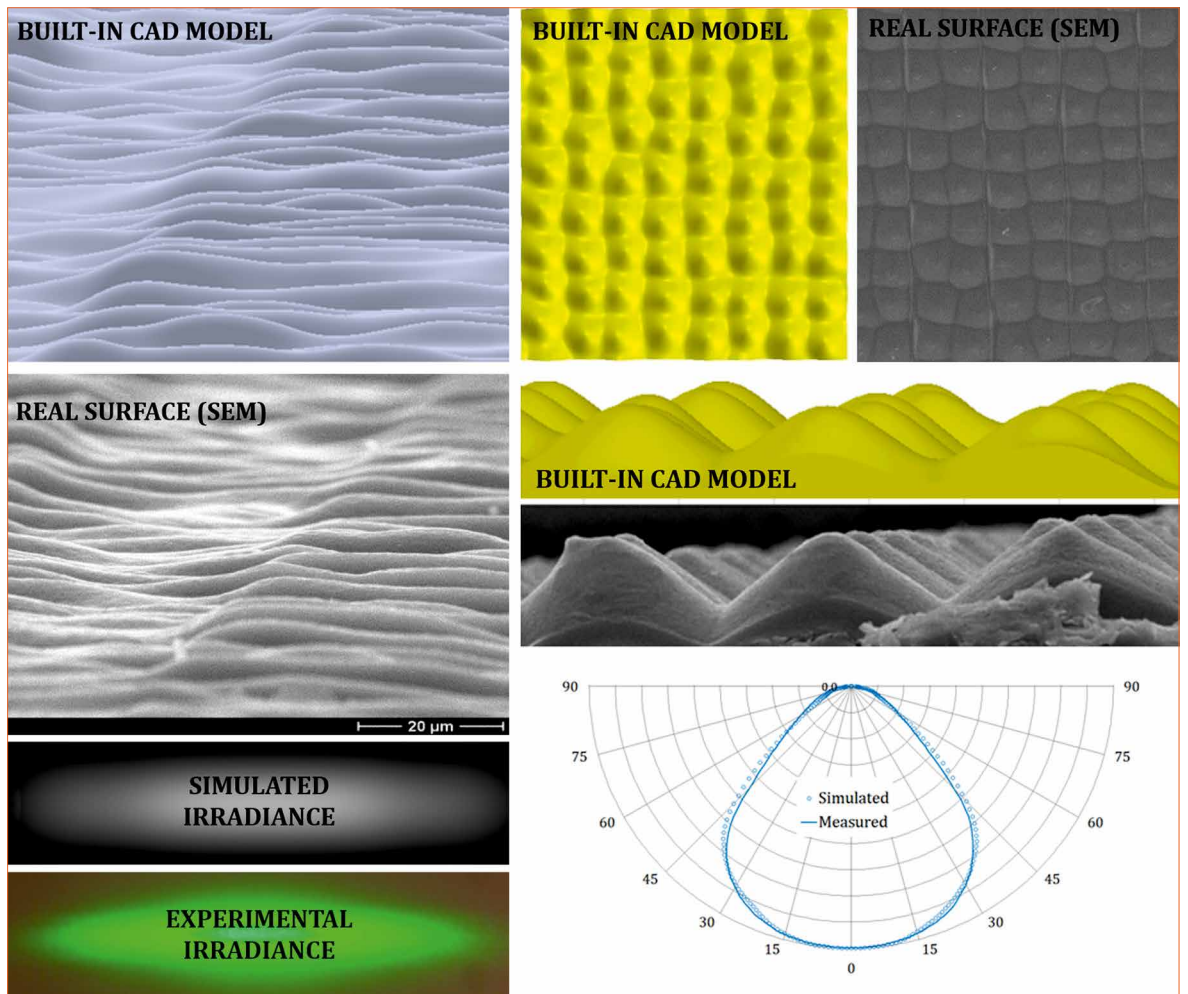

show the great agreement between the CAD models and SEM pictures as well as between the predicted and observed optical performance.

The CAD-model of the BrightView G-CG90 foil was illuminated by a flat Lambertian white light source and the luminous intensity measured using ANSYS SPEOS far-field polar EULUMDAT detector (Figure 3). The real sample was measured in

combination with an OLED lighting device (PhillipsLF300) and the intensity distribution curve measured using a goniophotospectrometer well beyond the far-field conditions in the C0-C180 plane. Again, the comparison, shown in figure 5 - right, shows a great agreement.

### Conclusions

FMLA technology is a powerful tool for optical design in many different applications fields. Since it is still at an early stage, this technology can progress much beyond its current status. However, further development can easily be frustrated by the lack of appropriate metrology solutions.

With support from advanced simulation tools such as ANSYS SPEOS semi-empirical procedures are possible for which, according to the results presented here, there is a large potential for the efficient and accurate characterization of FMLAs. Three aspects must nonetheless be addressed before we can fully evaluate the merit of the proposed method.

On the one hand, the lack of standard formats to describe FMLAs imposes multiple intermediate format conversions steps using different software tools, which not only is rather inconvenient but also susceptible to cumulative errors. The authors believe that efforts

towards the standardization of the FMLAs will not only facilitate their characterization but also allow a better interface and improve the communication and mutual understanding between optical designers and manufacturers.

On the other hand, although we have so far restricted the study to qualitative comparisons, a full evaluation of the method demands for quantitative tests. Such work is planned at CSEM and the results will be reported elsewhere.

Finally, it must be mentioned that this work has focused solely on form accuracy and ignored effects arising

from the non-negligible roughness of the involved surfaces and their optical effects, primarily specular reflectivity and light scattering [47]. On one size, the profilometer used for this work cannot measure sub-micron features with good lateral resolution. This could be addressed using more precise surface profilers (e.g. AFM, SEM, white-light interferometers and confocal laser microscopes) albeit the increase in the point density and the concomitant complexity of the resulting CAD model would need to be handled appropriately. ■

#### Notes:

[i] <http://www.resurf3d.com/Pointcloud2Nurbs.htm>

[ii] <https://www.solidworks.com/>

[iii] Attempts to convert the point-cloud directly in SolidWorks using the ScanTo3D add-in rendered meshes with a large number of errors including holes, faulty surface normals and self-intersections.

[iv] <https://www.ansys.com/products/optical/ansys-speos>

[v] <https://polyscale.com/en/products/optical-films/>

[vi] <https://www.rpcphotonics.com/product/eds-50/>

[vii] <https://www.brightviewtechnologies.com/products/led-diffusers/elliptical-led-diffusers/page.aspx?id=1121>

[viii] <https://www.brightviewtechnologies.com/products/light-management/glare-control-diffusers/page.aspx?id=1132>

#### References:

- [1] Zappe, H. (2012). Micro-optics: a micro-tutorial. *Advanced Optical Technologies*, Vol. 1, No. 3; pp. 117-126;
- [2] Reinhard Völkel (2012). Wafer-scale micro-optics fabrication. *Advanced Optical Technologies*, Vol. 1, No. 3; pp. 135-150
- [3] T. Zhou, X. Liu, Z. Liang, y. Liu, J. Xie and X. Wang (2017). Recent advancements in optical microstructure fabrication through glass molding process, *Front. Mech. Eng.* Vol. 12, No. 1; pp. 46-65
- [4] Hutley, M, Stevens R. and Daly, D (1991). Microlens arrays, *Physics World*, 4 (7), pp. 27-32
- [5] Reinhard Völkel, Hans Peter Herzig, Philippe Nussbaum, Rene Dandliker and William B. Hugle (1996). Microlens array imaging system for photolithography, *Opt. Eng.* 35 (11), pp. 3323-3330
- [6] Tingxiu Hou, Chong Zheng, Shi Bai, Qian Ma, Denzel Bridges, Anming Hu, and W. W. Duley. Fabrication, characterization, and applications of microlenses, *Appl. Opt.* 54, 7366-7376 (2015)
- [7] [https://www.3m.com/3M/en\\_US/industrial-manufacturing-us/display-enhancement-and-protection-films-industrial-manufacturing/display-enhancement-films/](https://www.3m.com/3M/en_US/industrial-manufacturing-us/display-enhancement-and-protection-films-industrial-manufacturing/display-enhancement-films/)
- [8] Ruidong Zhu, Qi Hong, Yating Gao, Zhenyue Luo, Shin-Tson Wu, Ming-Chun Li, Seok-Lyul Lee, and Wen-Ching Tsai (2015). Tailoring the light distribution of liquid crystal display with freeform engineered diffuser, *Opt. Express* Vol. 23, No. 11; pp. 14070-14084
- [9] James Gourlay (2015). Making Light Work Light Sources for Modern Lighting Requirements, *LED Professional Review*, Issue 47; pp. 72-75
- [10] Hyun Soo Kim, Seong Il Moon, Dong Eui Hwang, Ki Won Jeong, Chang Kyo Kim, Dae-Gyu Moon Chinsoo Hong (2016). Novel fabrication method of microlens arrays with High OLED outcoupling efficiency, *Optics & Laser Technology*, Vol. 77; pp. 104-110
- [11] Jui-Wen Pan, Chih-Ming Wang, Hsiao-Chin Lan, Wen-Shin Sun, and Jenq-Yang Chang (2007). Homogenized LED-illumination using microlens arrays for a pocket-sized projector, *Opt. Express* Vol. 15, No. 17; p. 10483
- [12] <https://www.brightviewtechnologies.com/>
- [13] K. Reutter, O. Fernandez, R. Ferrini, C. Hochfilzer and T. Dreyfus, OPTICAL FILM AND LIGHT FIXTURE WITH SUCH AN OPTICAL FILM; WO2017050929 (A1) — 2017-03-30
- [14] Selin Ashaboglu, Object of the Moment: 3M Daylight Redirecting Film by 3M, *Architectural lighting, daylighting and solar control*, March 02 (2017). Available on-line: [https://www.archlighting.com/products/daylighting-and-solar-control/object-of-the-moment-3m-daylight-redirecting-film-by-3m\\_s](https://www.archlighting.com/products/daylighting-and-solar-control/object-of-the-moment-3m-daylight-redirecting-film-by-3m_s)

- [15] Helmut F.O. Mueller (2017). Micro-optical structures for daylighting and led systems, *Renew. Energy Environ. Sustain.* Vol. 2, No. 29; DOI: 10.1051/rees/2017044
- [16] New World Record for Concentrator Photovoltaics 36.7 Percent for New Solar Module Using Highly Efficient Multi-Junction Solar Cells. <https://www.ise.fraunhofer.de/en/press-media/press-releases/2014/new-world-record-for-concentrator-photovoltaics.html>
- [17] V. Bardinal, T. Camps, B. Reig, D. Barat, E. Daran and J. B. Doucet (2011). Collective Micro-Optics Technologies for VCSEL Photonic Integration, *Advances in Optical Technologies*, Article ID 609643, 11 pages; doi:10.1155/2011/609643
- [18] <http://hamamatsu.magnet.fsu.edu/articles/microlensarray.html>
- [19] Leica announces M10 with new sensor, slimmer design, *DPRReview*. Available online: <https://www.dpreview.com/news/8915550991/leica-announces-m10-with-new-sensor-slimmer-design>
- [20] N. F. Borelli (2005), *Microoptics Technology*, Marcel Dekker
- [21] Reinhard Voelkl, Andreas Bich and Kenneth J. Weible and Maik Zimmermann (2008). Highly efficient array generators based on modern micro optics. *Dimensionally accurate micro optics*, *Optolines* No. 16; pp.12-14
- [22] Boswell, B., Islam, M.N. & Davies I.J (2018). A review of micro-mechanical cutting, *Int. J. Adv. Manuf. Technol.* 94: 789
- [23] Svyatoslav Voloshynovskiy, Maurits Diephuis, Taras Holotyak, and Nabil Standardo (2014). Physical object identification using micro-structure images, *SPIE Newsroom*. DOI: 10.1117/2.1201411.005524
- [24] S. Palm (2012). Micro-optics technology for ID applications. Promising overt banknote security feature for use in secure documents, *Keesing Journal of Documents & Identity*, June 2012, pp. 1-3.
- [25] Richard A. Steenblik, Mark J. Hurt, Michael E. Knotts (2002). Advantages of micro-optics over holograms for document authentication, *Proceedings Volume 4677, Optical Security and Counterfeit Deterrence Techniques IV*
- [26] <http://www.fresnelsinc.com/products.html>
- [27] P. Benitez and J. C. Miñano. The Future of Illumination Design, *OPN* May 2007 pp.20-25
- [28] Fabian Duerr, Youri Meuret, and Hugo Thienpont. Potential benefits of free-form optics in on-axis imaging applications with high aspect ratio, *Opt. Express* 21, 31072-31081 (2013)
- [29] E. Chen, R. Wu and T. Guo (2014). Design a freeform microlens array module for any arbitrary-shape collimated beam shaping and color mixing, *Optics Communications* 321; pp. 78 85
- [30] Kevin P. Thompson and Jannick P. Rolland (2012). Freeform Optical Surfaces: A Revolution in Imaging Optical Design, *Optics & Photonics News* Vol. 23, No. 6; pp. 30-35
- [31] L. Li and A. Y. Yi (2011). Design and fabrication of a freeform microlens array for uniform beam shaping, *Microsyst. Technol.*, 17:1713 1720; DOI 10.1007/s00542-011-1359-y
- [32] F.Z. Fang, X.D. Zhang, A. Weckenmann, G.X. Zhang, C. Evans (2013). Manufacturing and measurement of freeform optics, *CIRP Annals - Manufacturing Technology*, Vol. 62, pp. 823 846
- [33] Fang, F., Zhang, N. & Zhang, X. (2016). Precision injection molding of freeform optics. *Advanced Optical Technologies*, Vol. 5, No. 4, pp. 303-324; doi:10.1515/aot-2016-0033
- [34] Jingfei Ye, Lu Chen, Xinhua Li, Qun Yuan, Zhishan Gao (2017). Review of optical freeform surface representation technique and its application, *Optical Engineering*, Vol. 56, No. 11; p. 110901
- [35] Timmo Gissibl, Simon Thiele, Alois Herkommer and Harald Giessen (2016). Sub-micrometer accurate free-form optics by three-dimensional printing on single-mode fibres, *Nature Communications* 7, article number: 11763
- [36] A. Broemel, U. Lippmann and H. Gross (2017). Freeform surface descriptions part I: Mathematical representations, *Adv. Opt. Techn.* Vol. 6, No. 5; pp. 327-336
- [37] Tasso RM Sales, Stephen Chakmakjian, G. Michael Morris and Donald J. Schertler (2004), *Light Tamers*. Engineered microlens arrays provide new control for display and lighting applications, *Photonics Spectra*, June Issue. Available on-line: [https://www.rpcphotonics.com/pdfs/Light\\_Tamers.pdf](https://www.rpcphotonics.com/pdfs/Light_Tamers.pdf)
- [38] Lei Li and Allen Y. Yi (2012). Design and fabrication of a freeform microlens array for a compact large-field-of-view compound-eye camera, *Appl. Opt.* Vol. 51; pp. 1843-1852
- [39] Hao Zhang, Lei Li, David L. McCray, Sebastian Scheiding, Neil J. Naples, Andreas Gebhardt, Stefan Risse, Ramona Eberhardt, Andreas Tunnermann and Allen Y. Yi (2013). Development of a low cost high precision three-layer 3D artificial compound eye, *Opt. Express*, Vol. 21, No. 19; DOI:10.1364/OE.21.022232
- [40] J. Dunkel, F. Wippermann, A. Reimann, A. Brückner and A. Bräuer (2015). Fabrication of microoptical freeform arrays on wafer level for imaging applications, *Opt. Express*, | Vol. 23, No. 25 | DOI:10.1364/OE.23.031915
- [41] Simon Thiele, Kathrin Arzenbacher, Timo Gissibl, Harald Giessen, Alois M. Herkommer (2017). 3D-printed eagle eye: Compound microlens system for foveated imaging, *Sci. Adv.* 2017; 3 e1602655 15
- [42] Nikhil Balram and Ivana Tošić (2016). Light-Field Imaging and Display Systems, *Information Display* Vol. 32, No. 4; pp. 6-13
- [43] <http://www.fovi3d.com/>
- [44] Bader Aldalali, Chenhui Li, Li Zhang and Hongrui Jiang (2012). Micro Cameras Capable of Multiple Viewpoint Imaging Utilizing Photoresist Microlens Arrays, *J. Microelectromechanical Systems*, Vol. 21, No. 4; pp. 945-952
- [45] W. Yuan, L-H. Li, W-B. Lee and C-Y Chan (2018). Fabrication of Microlens Array and Its Application: A Review, *J. Mech. Eng.* 31:16; <https://doi.org/10.1186/s10033-018-0204-y>
- [46] H. Hua and B. Javidi (2015). Augmented Reality: Easy on the eyes (2015), *Optics & Photonics News*, Vol. 26, No.2; pp. 26-33
- [47] S. Singh, H. Solak, and F. Cerrina (1996). Multilayer roughness and image formation in the Schwarzschild objective, *Review of Scientific Instruments* Vol. 67, No. 9; pp. 3355 - 3355; <https://doi.org/10.1063/1.1147374>



LpS 2019

LED SYMPOSIUM  
professional + EXPO



**The lighting event  
for technologies  
of tomorrow**

Early Bird Tickets  
Now available!  
[www.lps2019.com](http://www.lps2019.com)

LpS is Europe's leading international lighting technologies conference and exhibition for **DESIGN, TESTING** and **PRODUCTION** of lighting systems, controls and equipment.

9<sup>th</sup> International LpS | September 24<sup>th</sup> - 26<sup>th</sup> 2019 | Bregenz | Austria

Organized by

LUGER RESEARCH  
Institute for Innovation & Technology



Co-hosted with



[www.lps2019.com](http://www.lps2019.com)

# Thermal and Optical Challenges for SSL in Automotive Applications

Solid State Lighting changed the lighting environment in automotive lighting almost more than in the field of general lighting. While efficiency of the devices increased and every few weeks new improvements are reported, thermal management remains crucial and a critical part of the system. Umut Zeynep Uras, Ahmet Mete Muslu and Mehmet Arik, from the Energy Efficient Electronics and Lighting Technologies Center (EVATEG), Department of Mechanical Engineering, College of Engineering at Ozyegin University, and Fatih Goren from the FARBA Corporation, explain the dependencies between photometric, electrical and thermal parameters of an automotive lighting application.

Automotive lighting experienced a major shift during the last decade due to inherent advantages of Solid State Lighting (SSL) products. Light emitting diodes (LEDs), a frontline runner for SSL technologies offer a wide color gamut, exceptional energy efficiency and affordability. However, their implementation poses some challenges for practical applications. Photometric, electrical and thermal properties of LEDs are highly interrelated. Therefore, while a lighting system is designed, those interrelated parameters of the system should be carefully considered to achieve desired performance metrics. Luminous efficacy of LED systems is highly sensitive to junction temperature of the LEDs because optical output of the LEDs changes with temperature. Therefore, designers should consider the dependency between electrical, photometric and thermal quantities to achieve optimal performance. In this study, dependency between photometric, electrical and

thermal parameters of an automotive lighting application is presented. It is found that novel thermal and optical technologies are necessary to reach next generation lighting systems for automotive lighting applications.

## Introduction

Today's automotive lighting systems basically include headlamp and rear lamp lighting systems whose development have continued over the last few decades. Headlamps' performance has been progressively improved throughout the series of developments. Acetylene or oil were used to run the earliest headlamps which were developed in the late 1880s. Then, a game changer headlamp technology, the first electric headlamp, was released to the market in 1898 [1]. After technology progressed over more than half a century, the first halogen lamp (H1) for use in vehicles as a headlamp was eventually presented in 1962. After that, headlamps running unique light sources started to appear in Europe [2,3]. One of these lighting sources, light-emitting diodes (LEDs), is effectively used today in automotive headlamp applications as they have undergone rapid development since 2004. In fact, the first full-LED headlamp was utilized on Audi R8 sports car [4]. These days, advances in LED automotive lighting have been progressively changed from high class car models to middle class models [5].

In fact, LED technology offers significant advantages in energy efficiency, lifetime, reliability and design in automotive lighting system compared to conventional lighting system [6,7]. The use of LED light sources in automotive lighting is especially important in terms of safety concerns since they react very quickly to electrical warnings. The lit time of an LED lamp is less than a standard bulb's in the order of milliseconds so that it makes a significant difference in braking distance when the vehicle is operated at a high speed [8]. One of the recent projections estimates that 20% of front headlights of light vehicles will be powered by LED products by 2030 compared to 2% in 2015 [9]. In fact, predictions show that LED headlamp sector will get bigger at a Compound Annual Growth Rate (CAGR) of 20% and dominate lighting technology. The expanded use of LEDs in front lighting applications is led by Europe and Japan where the LED penetration is expected to be 36% and 45% respectively by 2030 but it was only about 4% and 6% in these regions in 2015 [10]. In addition to upper segment vehicles, LED systems have also started to appear in lower segments recently. The inclusion of LEDs in automotive lighting is expected to be even more when the emerging trends in autonomous vehicles, internet of things and visible light communication are considered [11,12,13]. Since LED technology brings great advantages due to its semiconductor nature, it will play a significant role in many fields. Cutting-edge technologies including AFS, ADB, glare free high beam, automatic leveling and matrix beam are all based on LED light sources and they are successful in illuminating a certain area effectively. Since recent systems include electronics systems with improved capabilities, technological advancements in automotive lighting is typically classified as 'digital lighting' today.

The trends in automotive exterior lighting can be grouped under front



**Figure 1:** Some examples of LED automotive exterior lighting products produced by FARBA Corporation for AUDI A8L (upper left), Volkswagen Touareg (upper right) and Mercedes E-Class Coupe (lower)

(headlamps) and back (rear lamps) lighting systems respectively [14,15]. While novel matrix systems, laser headlamps, LCDs and digital micro-mirror devices (DMD) are the rising trends in future headlamp systems, integration of OLEDs and Micro Lens Arrays (MLAs) into rear lamp systems is also intended for future applications. Considering the trends in front lighting, today's matrix systems are only utilized as a high beam function and still improved. The matrix systems in future applications, however, will combine the low and high beam functions. Thus, they will be able to adapt to driving conditions using a simpler structure. This will allow switching between high and low beams through sensors according to the incoming traffic data [16]. LCD systems with a number of LED chips and micro-optics are also integrated into the headlights as they can enable high-definition illumination. Although the use of an LCD to obtain an adaptive headlamp is first offered in 1989 [17],

the current integration of an LED matrix on LCD systems offer new opportunities to reach a resolution at approximately 50000 pixels. Furthermore, digital micro-mirror devices (DMDs) are systems that can focus light to a certain point by electronically moving hundreds of thousands of micron-level mirrors. Each microscopic mirror over the surface represents the pixel of an image and they can be rotated by  $\pm 10-12^\circ$  to ON or OFF state. In the ON state, the pixel is made bright on the screen as the lens is exposed to the reflected light from the light source and it is made dark in the OFF state when the light is forwarded to another field [18].

In addition to front lighting, there are also various ideas that make scientists and engineers eager to improve back lighting in the automotive industry. First, OLEDs are utilized only in signaling functions today in automotive lighting since they have much lower luminance than LEDs. Therefore,

**Table 1:**  
Power consumption  
of a typical LED over  
a PCB of a Daytime  
Running Lamp (DRL)

LED temperature (°C)	Voltage (V)	Current (A)	Electrical power (W)	Heat generation (W)
30	3.005	0.264	0.793	0.5753
50	2.946	0.265	0.782	0.5674
70	2.893	0.267	0.772	0.5599
100	2.821	0.269	0.760	0.5513
120	2.777	0.271	0.752	0.5453

**Figure 2:**  
FR4 based LED light  
engine LEDs' side (a),  
electronics' side (b)

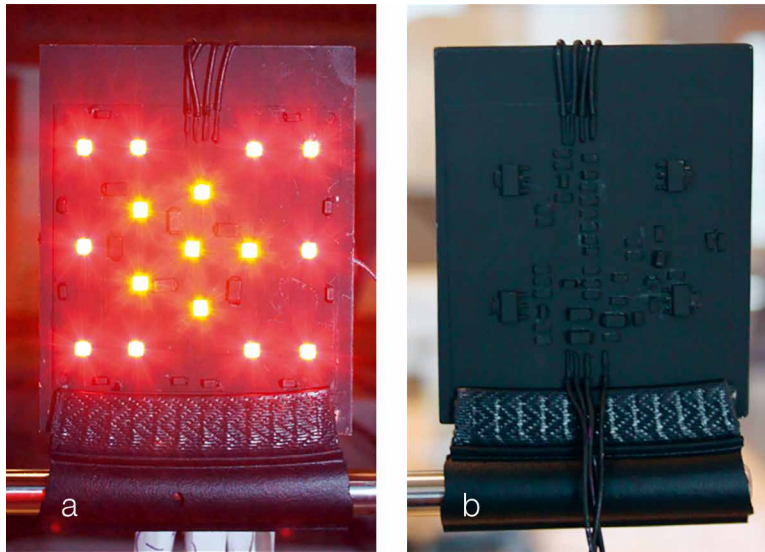

**Figure 3:**  
Experimental  
setup for electrical  
measurements

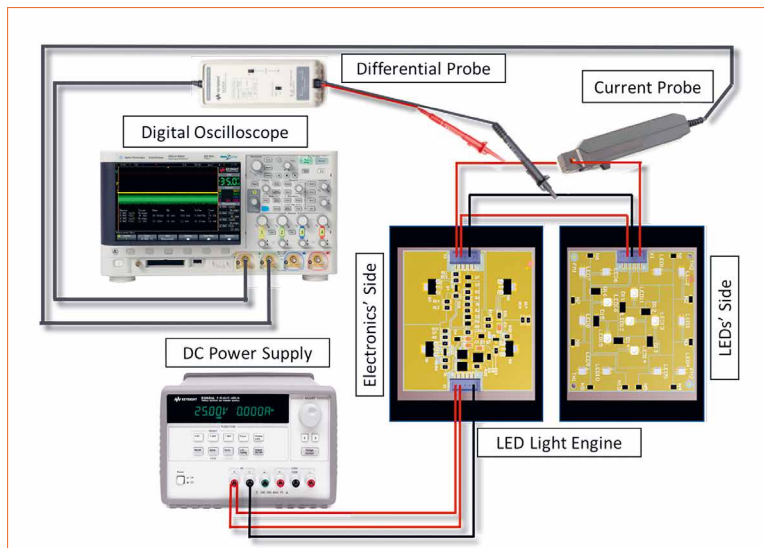

researchers are paying attention to the increase of lumen output of OLEDs for future applications. Furthermore, although micro lens arrays (MLAs) have been currently used in various entertainment units of micro-projectors, they can also be utilized in projecting light in the shape of certain signs or warnings on the road or pedestrian walk surface and this could bring a lot of benefits in traffic.

Although these technologies are under development for future applications, optothermal problems and reliability issues associated with them arises because of high power conditions over a limited space. Table 1 shows the consumed electrical power and generated thermal power values of a typical LED over a PCB of a Daytime Running Lamp (DRL) measured at various LED solder temperatures in

a range of 30° to 120°C. The optical conversion efficiency was determined as 27.45% [8].

The resulting elevated temperatures of LEDs do not only cause reduced lifetime but also lead to a significant drop in the amount of generated light and optical efficiency. In fact, the dependency of optical, electrical and thermal characteristics of LEDs needs to be addressed for the integration of these novel technologies to the current applications. Thus, this study focuses on determining the relationship between optical, electrical and thermal traits of LEDs for automotive applications.

In this study, a test board with multiple amber and red LEDs is designed and manufactured to mimic an automotive LED lighting PCB. This LED light engine with a conventional flex FR4 based PCB is used to understand the relationship between optical, electrical and thermal characteristics of red and amber LEDs. Usually an FR4 LED light engine is used in an exterior rear lighting system of automobile. It has a double-sided structure having electronics at the front and LEDs at the back side (Figure 2). Identical FR4 flex PCBs with a thickness of 200 µm are attached to FR4 substrate with the dimensions of 66x80x2.75 mm. There are 10 red LEDs and 6 amber LEDs at the front side and driver electronics exist at the back side of the engine.

FR4 based LED light engines are driven at 6 different power levels. First, only red LEDs are driven at six different input electrical powers between 0.5 and 3W. Then, only amber LEDs are separately driven at the same input powers. In order to determine the input power of the LEDs, electrical measurements are conducted with a digital oscilloscope. There are two branches in parallel for the electrical connection of red LEDs and serially connected five red LED chips are placed at each branch. Six amber LED chips, however, are connected in series in the SIGNAL branch.

FR4 based LED light engine is connected to a power supply with position, stop and ground cables. Both differential and current probes are connected to an oscilloscope for this measurement. Thus, voltage difference across one of the branches and electrical current passing through that branch are determined. The setup for electrical measurements of LEDs is given in Figure 3.

The measurements were conducted for various power levels in the range of 0.5 W and 3 W. As it is noticed in figure 4, the growth of electrical input power of both LEDs decreases and its ratio to total input power decreases as the LEDs are driven at higher electrical power levels. At the lowest total input power of the circuit, 80% of this power (494.5 mW) is supplied to red LEDs while only 33.5% of total input power is given to the same LED at the highest input power. A similar case is also observed for the amber LEDs. As 91.2% of total input energy is provided to the amber LED at the minimum power level, it reduces to 64.5% when the input power is elevated to the highest level.

In addition, thermal experiments were conducted for each LED color and power condition to observe the change in thermal characteristics of the LED light engine. Red LEDs and amber LEDs were separately operated in two cases for six different power conditions. Total input powers supplied to the LED light engine in these experiments were 500 mW, 1000 mW, 1500 mW, 2000 mW, 2500 mW and 3000 mW. While input power provided to only red LEDs were 396 mW, 737 mW, 879 mW, 931 mW, 968 mW and 997 mW, they were 433 mW, 907 mW, 1284 mW, 1606 mW, 1835 mW and 1929 mW for amber LEDs.

IR thermal images of the FR4 based LED light engine at different input power levels are presented for red and amber LEDs in figures 5 and 6 respectively. While electronics

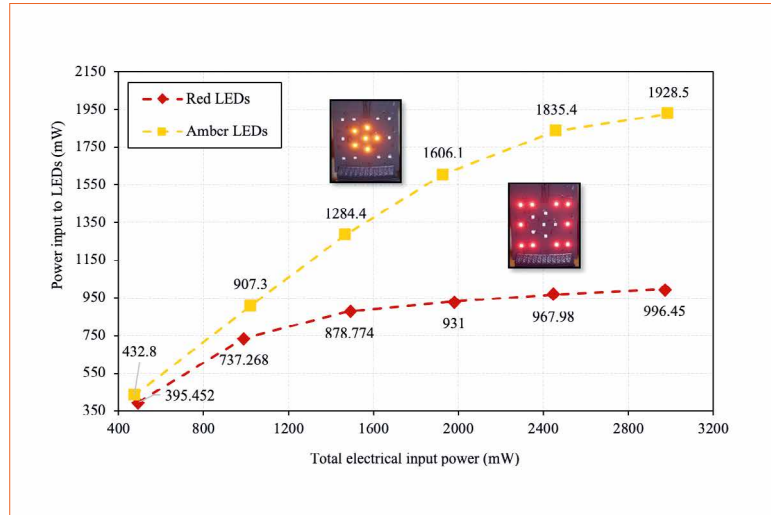

**Figure 4:** Change in electrical input power of red and amber LEDs with respect to total electrical input power to PCB

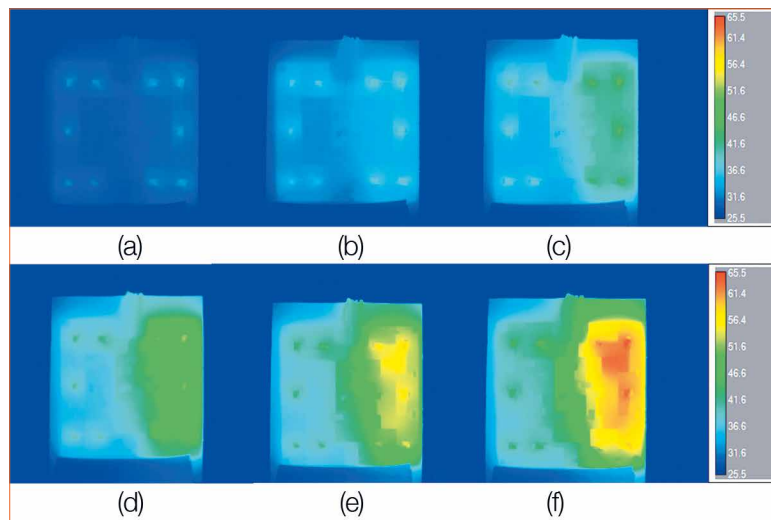

**Figure 5:** IR thermal images of the LED light engines when electrical input power of red LEDs is (a) 396 mW, (b) 737 mW, (c) 879 mW, (d) 931 mW, (e) 968 mW & (f) 997 mW

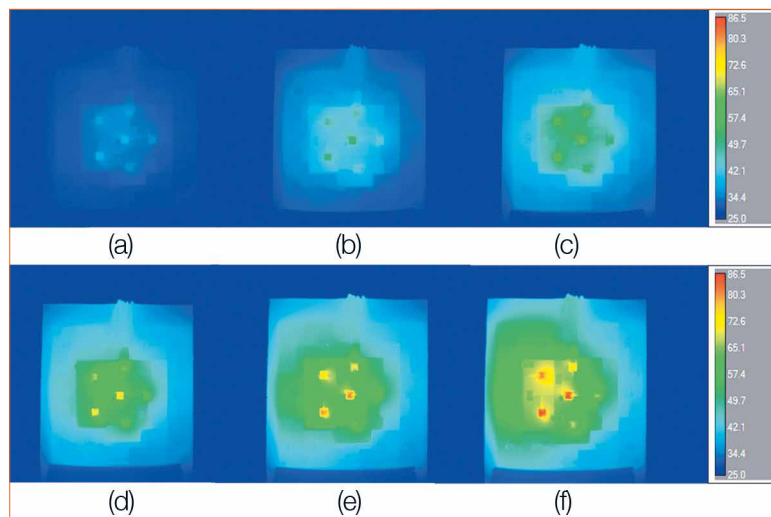

**Figure 6:** IR thermal images of the LED light engines when electrical input power of amber LEDs (a) 433 mW, (b) 907 mW, (c) 1284 mW, (d) 1606 mW, (e) 1835 mW & (f) 1929 mW

operated to drive red LEDs are given in figures 5c, 5d, 5e, and 5f, electronics in charge of driving amber LEDs are located on the right-hand side of the electronics side of the engine which corresponds to the left-hand side of the LEDs' side of the engine. As it is indicated in figure 5,

hot spots over the red LEDs become more critical as input power increases. Temperature of the right-hand side of the LED light engine where LED1, LED2, LED3, LED4 and LED5 are placed is higher and several local hot spots are observed over these LEDs. Thus, nonuniform temperature distribution

is experienced over the LED light engine. On the other hand, local hot spot firstly forms around amber LEDs as seen in figure 6. It can be inferred from the figure that hot spots expand to surrounding of these LEDs as input power starts to increase. In the last two experiments, temperature of the left-hand side became higher and local hot spots appeared more explicitly over LEDs 12, 15 and 16.

Maximum temperatures of red and amber LEDs at six different power conditions are presented in figures 7 and 8 respectively. A linear increase is observed in maximum

temperature of the red LED 6, 7, 8, 9 and 10 and all amber LEDs. However, maximum temperature of certain red LEDs (LED 1, 2, 3, 4, and 5) and amber LEDs (LED 15 and 16) exhibits a sharp increase after a specific input power value. This happens after the second lowest input power level around 737 mW for red LEDs and the second highest input level around 1835 mW for amber LEDs due to the heat dissipation from the electronics at the back side. It is also noticed that the slopes of the first 5 red LEDs are approximately twice of the slopes of the other 5 LEDs.

Figure 9 shows the maximum temperature of red and amber LEDs. While x-axis shows total heat generation of red and amber LEDs, which is calculated as the difference of total input power of the LEDs and total radiant flux of the LEDs, y-axis shows the change in temperature of LED 2 and LED 12, which reach the highest surface temperature among ten red and six amber LEDs respectively. In addition to the supplied electrical power on LEDs, heat conduction from operated electronics also led to a temperature rise of LED 2 and LED 12. Therefore, the increasing rate of the maximum LED temperature is more than total heat generation's.

**Figure 7:** Maximum temperatures of red LEDs at different electrical input powers

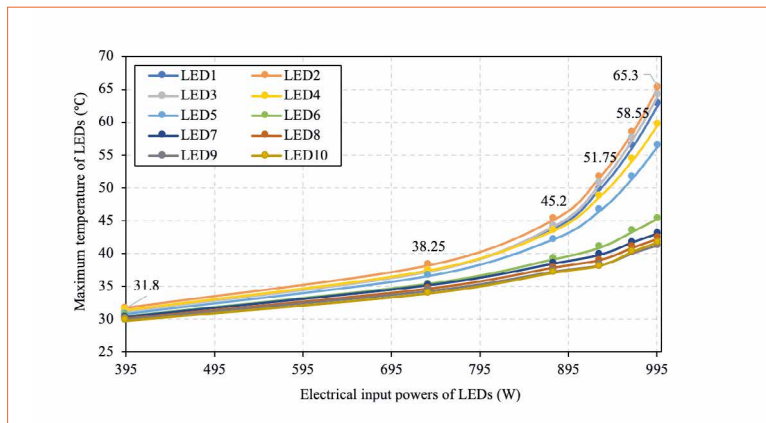

**Figure 8:** Maximum temperatures of amber LEDs at different electrical input powers

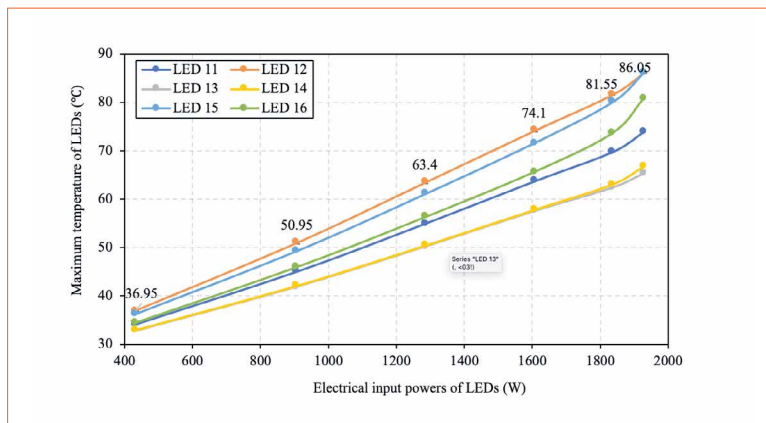

**Figure 9:** Maximum LED temperature with respect to total heat generation of red and amber LEDs

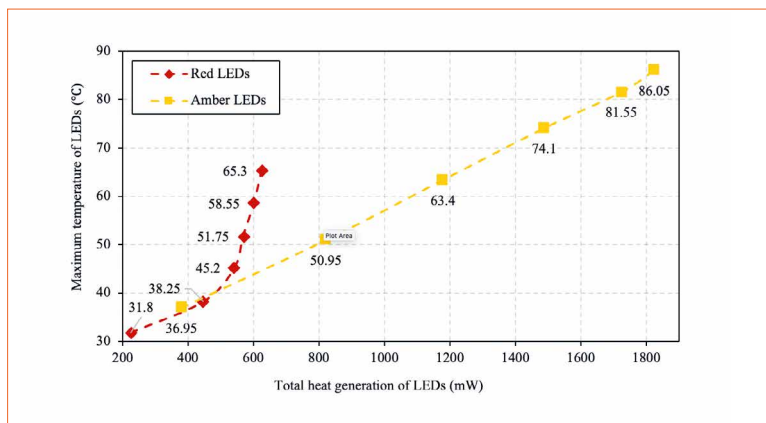

**Optical Measurements**

After electrical and thermal experiments, optical experiments were conducted on the same LED light engine to determine photometric and radiometric characteristics of the light engine. Optical experiments were conducted on FR4 based LED light engine with FR4 flex PCB at various power conditions. Optical spectrum of red and amber LEDs at the given power conditions are presented in figures 10 and 11 respectively. It is seen that peak wavelength shifts towards the right due to an increase in the input power and bandgap energy shrinkage. In fact, bandgap energy is temperature dependent because of electron-phonon interactions and lattice vibrations [19].

During red LED tests, as total input power supplied to LED light engine is elevated by 2.5 W, peak wavelength shifts by 4 nm. On the other hand, as the input power of amber LEDs is raised from 0.5 W to 2 W, peak wavelength shifts right by 6 nm and radiant flux at peak wavelength rises by 1.7 mW. When the input power of amber LEDs is altered from 2 W to 4 W, peak wavelength shifts right by 3 nm and radiant flux at peak wavelength drops by 0.8 mW. Therefore, the efficiency decrease can be inferred from the drop in relative radiant flux.

September 24–26, 2019  
Opera House Bregenz

# 2019



# TRENDS IN LIGHTING

for Architects  
Lighting Designers  
Planners  
Investors

3rd International Trends  
in Lighting Forum & Show

Human Centric Lighting  
Light Quality & Visual Perception  
Smart Lighting & IoT  
Lighting Technologies  
Best Practice for Smart Buildings & Cities  
Investment, Business & Process  
Networking & Inspiration

[www.TiL2019.com](http://www.TiL2019.com)



**EARLY BIRD  
TICKETS**  
available until July 2nd



**Figure 10:**  
Flux spectrum of red LEDs at various electrical power conditions

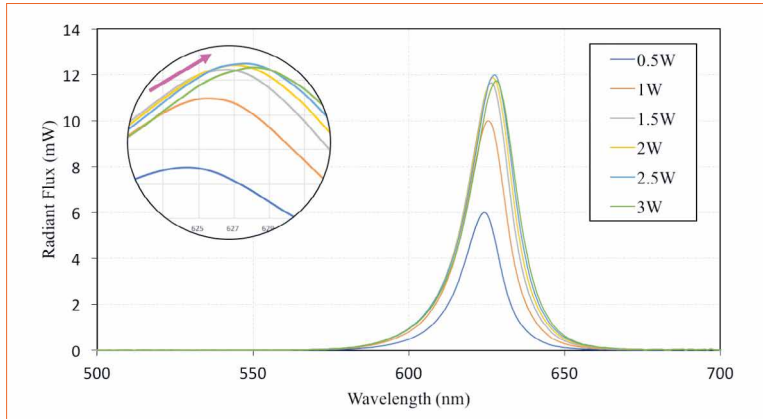

**Figure 11:**  
Flux spectrum of amber LEDs at various electrical power conditions

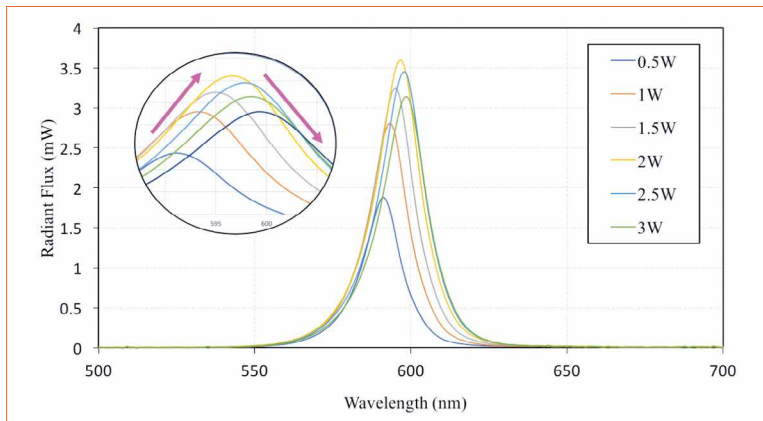

**Figure 12:**  
Change in peak wavelength with respect to electrical input power of red and amber LEDs

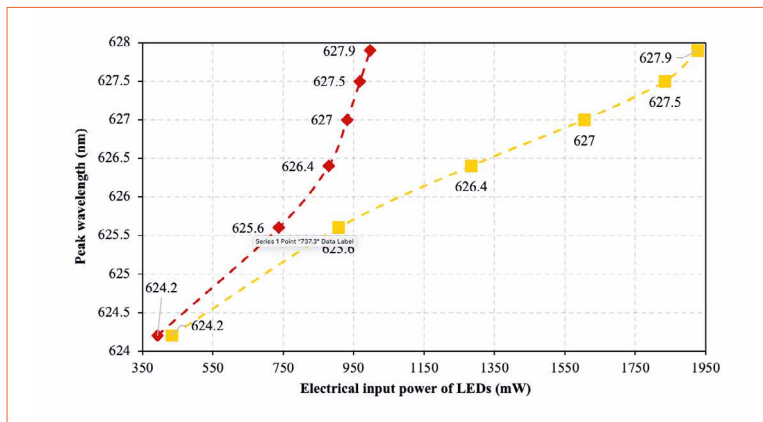

**Figure 13:**  
Variation of radiant power with electrical input power of red and amber LEDs

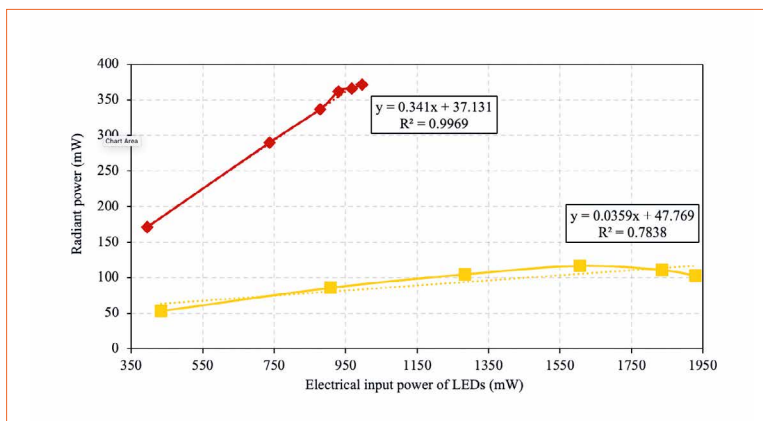

Figure 12 demonstrates the peak wavelength increment with respect to input electrical power of the LEDs. Peak wavelength rise of red

LEDs accelerates after the third lowest power condition due to junction temperature elevation. In amber LEDs, the increase in

peak wavelength accelerates at the highest power condition.

Radiant power change with respect to input power of the red and amber LEDs are presented in figure 13. Although there is a linear relationship between radiant flux and input power of red LEDs, radiant flux is raised by 2.5% as input power increases by 7% at the last three power conditions. However, after some point, radiant flux starts to decrease although input power increases. While input power of amber LEDs is elevated, junction temperature of the LEDs also increases due to the ineffective thermal management of FR4 based LED light engine. Because of the rise in junction temperature, optical output of the LED drops in this case.

As input power of red LEDs increases from 395.5 mW to 996.5 mW, luminous efficacy decreases by 13.6 lm/W as seen in figure 14. A sharp fall in luminous efficacy is experienced in the last case compared to the first five cases since junction temperature rises more at higher driving currents. On the other hand, as input power of amber LEDs increases from 432.8 mW to 1928.5 mW, luminous efficacy decreases by 24.6 lm/W. Until the fourth experimental case, luminous efficacy increases slowly, after that it starts to decrease with a positive acceleration. The fall in the luminous flux causes a decrease in luminous efficacy. As a result, the power level of 1600 mW is critical for amber LEDs.

### Results and Discussions

Thermo-electro-photometric relationship is developed for red and amber LEDs for an automotive exterior lighting system. Discussion for thermo-electro-photometric relationship begins with red LEDs and continues with the amber LEDs. As it is suggested in figure 15, heat generation of both red and amber LEDs increases linearly as input LED power is elevated.



However, due to the additional effect of heat generation of the electronics, maximum LED temperatures of red and amber LEDs rise growingly.

Figure 16 shows the change in luminous flux with respect to input power of red and amber LEDs. It is noticed that luminous flux of red LEDs does not change significantly when input LED power exceeds 879 mW while luminous flux of the amber LEDs starts to decrease after the input LED power of 1606.1 mW. Thus, driving LEDs with the input powers after certain point is ineffective for automotive lighting systems. A similar trend is observed for both LEDs in the change of luminous flux and maximum LED temperature with respect to input LED power. An inverse relationship between junction temperature and luminous flux can be inferred from the graph. As it is also shown in the graph, the increasing rate of the maximum temperature slightly rises at the last power condition.

As it is experimentally observed, input electrical power is converted to radiant energy and heat generation. The amount of heat generation varies depending on the performance of cooling technologies in lighting systems. Figure 17 indicates the change in radiant flux and heat generation of red and amber LEDs with respect to LED electrical power. When input power of red LEDs is 395.5 mW, 43% of the electrical power turns into radiant flux. However, if it is raised to 996.5 mW, 37% of the electrical power is converted into radiant flux. In the case of amber LEDs, when the input power of the amber LEDs is 432.8 mW, 12% of the electrical power turns into radiant flux. On the other hand, if it is elevated to 1928.5 mW, only 5% of the electrical power results in radiant flux. Consequently, the conversion rate of the red and amber LEDs decreases by 6% and 7% respectively because of the increase in junction temperature.

The conversion rate is presented with respect to maximum LED

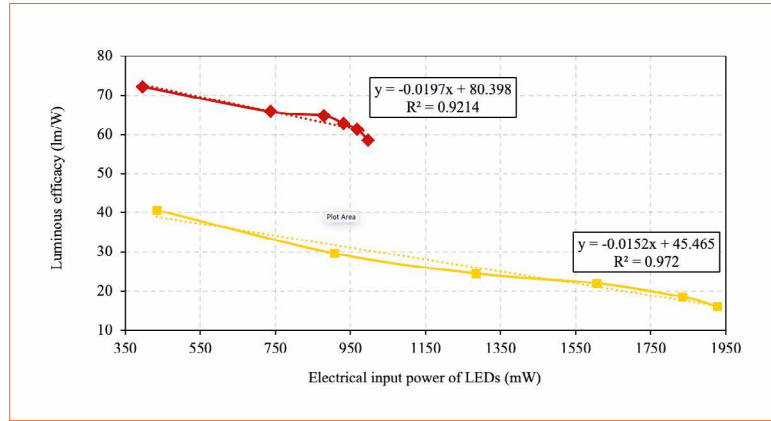

Figure 14: Change in luminous efficacy with respect to electrical input power of red and amber LEDs

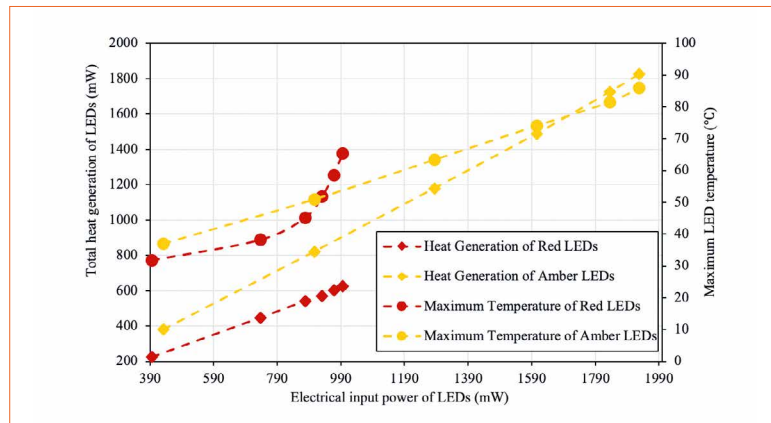

Figure 15: Change in total heat generation and maximum LED temperature with respect to input electrical power

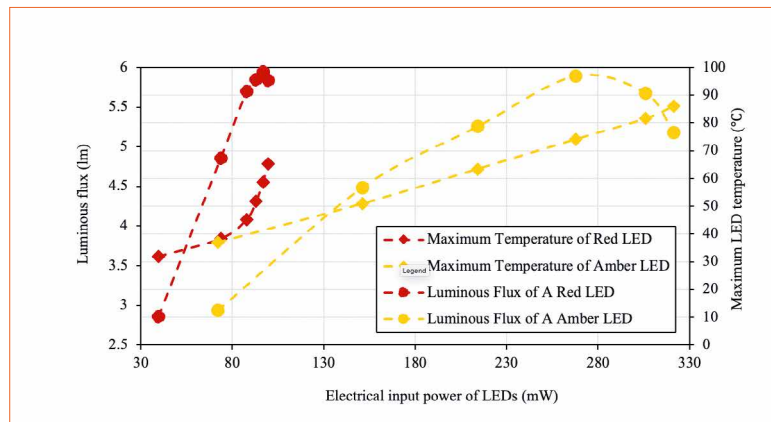

Figure 16: Change in luminous flux of LEDs and maximum LED temperature with respect to electrical input power

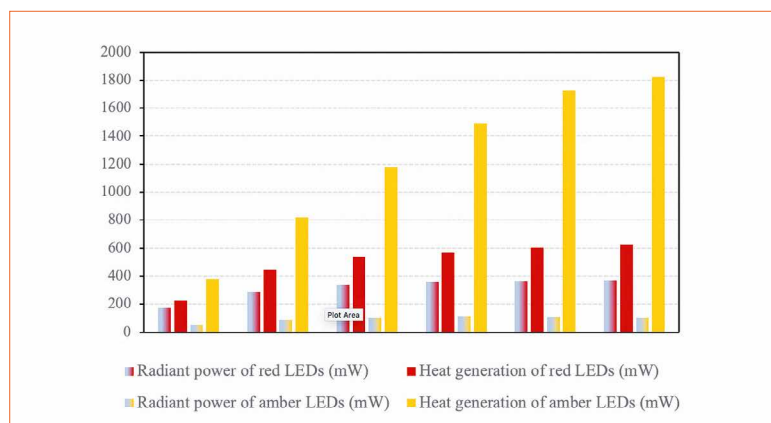
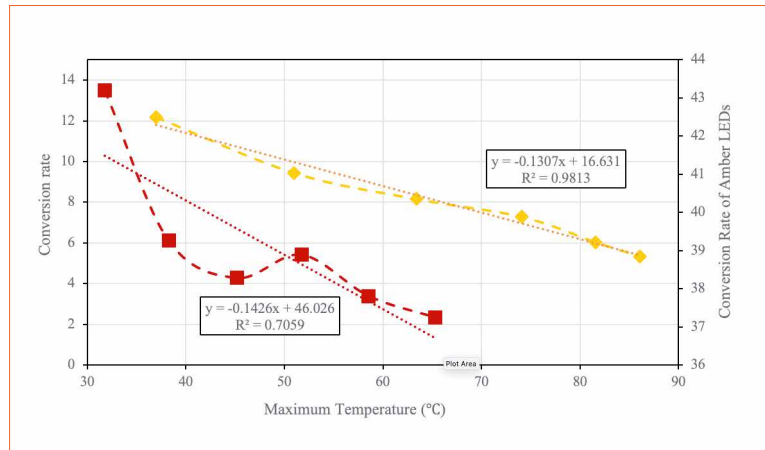

Figure 17: Amount of heat generation and radiant flux of LEDs at various driving conditions

temperature in figure 18. A relationship between maximum surface temperature of an LED and the conversion rate is developed.

While maximum temperature increases, the conversion rate of the LED decreases. This correlation is generated for a multi-chip LED

**Figure 18:**  
Relation between maximum LED temperature and conversion rate for amber LEDs



board and it is assumed that all LEDs have identical radiant power and LED temperature. However, due to nonuniform heat distribution, LEDs may have different radiant flux and temperatures.

### Summary and Conclusions

LEDs are now widely accepted for a large number of applications from general lighting to displays, automotive lighting to horticultural use. In this study, we have

presented a number of thermal, electrical and optical challenges for automotive lighting applications. It is found that LEDs with over 5x efficiency and 8x lifetime expectancy compared to conventional lighting products, will quickly replace conventional automotive lighting products. However, cost is still a burden and slows the penetration. While high end vehicles started quickly adapting these technologies, there is still some room for improvement of those products. High junction temperature, optical distribution problems, glare over other drivers and pedestrians, lifetime and electronics packaging at compact volumes still pose challenges for the industry. ■

### Acknowledgement:

Authors thank to EVATEG Center at Ozyegin University for enabling the use of computational and experimental facilities as well as FARBA Corporation for providing test samples for the experimental studies.

### References:

- [1] Georgano, G. N. (2002). "Cars: Early and Vintage", 1886-1930 (A World of Wheels Series), Mason Crest, ISBN 978-1-59084-491-5
- [2] Moore, D. W., 1998, "Headlamp History and Harmonization", University of Michigan, Transportation Research Institute
- [3] Grueninger., W., 2010, "The Difference Between US and European Lights". [Online] Available: [www.motivemag.com/pub/feature/tech/Motive\\_Tech\\_The\\_Difference\\_Between\\_US\\_and\\_European\\_Lights.shtml](http://www.motivemag.com/pub/feature/tech/Motive_Tech_The_Difference_Between_US_and_European_Lights.shtml).
- [4] Hanlon, M., (2009, January 4), "Audi R8 V10 becomes first all-LED car", [Online] Available: "newatlas.com/audi-r8-v10-becomes-first-all-led-car/10655"
- [5] TrendForce, 2014, "LED Manufacturers Will Uplift the Technology Entry Level and Find New Applications in Hopes to Raise Profitability in 2015", Press Release. [Online] Available: "press.trendforce.com/press/20141215-1761"
- [6] Kovac, J., Peternai, L., and Lengyel O., 2003, "Advanced light emitting diodes structures for optoelectronic applications", Thin Solid Films, Elsevier, Volume 433, Issues 1-2, pp. 22-26
- [7] Eichhorn K., 2006, "LEDs in automotive lighting", Proc. SPIE 6134, Light Emitting Diodes: Research Manufacturing, and Applications X, Integrated Optoelectronic Devices 2006, San Jose, California, United States
- [8] Özdil, İ., 2015, "Otomotiv Aydınlatma Sistemlerinde Kullanılan LED'li Elektronik Devre Kartlarının Hesaplamalı Isıl Analizi" Master Thesis, Uludağ University Institute of Science and Technology, Mechanical Engineering
- [9] Driving Vision News (DVN), 2016, "LED Headlamps: 20% by '30?", [Online] Available: "www.drivingvisionnews.com/news/lighting/74"
- [10] Roberts, G., 2016, "LED headlights forecast to be on one in five cars by 2030 just auto's QUBE", QUBE - accurate lighting sector insights
- [11] Florentine, E., Andersen, H., Ang, M. A., Pendleton, S. D., Fu, G. M. J., and Ang, M. H. Jr., 2015, "Self-Driving Vehicle Acknowledgement of Pedestrian Presence Conveyed via Light-emitting Diodes", Humanoid Nanotechnology Information Technology Communication and Control Environment and Management (HNICEM) International Conference on. IEEE, pp. 1-6, 2015
- [12] Arik, M., and Uras, U.Z, 2017, "Thermal Issues Posed by Compact Packaging and IoT for Next Generation SSL", LED Professional, LpR64 Nov/Dec 2017, pp. 44
- [13] Chi, N., Wang, Y., Wang, Y., Huang, X., and Lu, X., 2014, "Ultra-high-speed single red-green-blue light-emitting diode-based visible light communication system utilizing advanced modulation formats," Chin. Opt. Lett. 12, 010605
- [14] Driving Vision News (DVN), 2014, "The Future of Automotive Lighting", Paris: DVN
- [15] Driving Vision News (DVN), 2016, "The Future of Automotive Lighting Report", Frankfurt: DVN
- [16] Valeo Service, 2018, "Valeo Matrix Beam Headlights Provide Better Visibility Without Blinding Oncoming Drivers", [Online] Available: "www.valeoservice.com/en-com/newsroom/valeo-matrix-beam-headlights-provide-better-visibility-without-blinding-oncoming-drivers"
- [17] Khanh, T.Q, 2015, in Proc. 11th International Symposium on Automotive Lighting, Volume 16, p. 499
- [18] Lee, B., 2018, "Introduction to ±12 Degree Orthogonal Digital Micromirror Devices (DMDs)", Texas Instruments, DLPA008B July 2008 Revised February 2018
- [19] Jing, W., Yumei, W., Ping, L. and Sanshan W., 2016, "Junction-temperature estimation in AlGaInP light-emitting diodes using the luminescence spectra method", Journal of Semiconductors, Vol.37, No.6, pp. 064010

# Shine a Light on Opportunity

## HKTDC Hong Kong International Lighting Fair (Spring Edition) 2019

is a strong trading platform with a global reputation. Organised by the Hong Kong Trade Development Council, the 2018 edition attracted more than 20,500 buyers from 114 countries and regions, and a record number of more than 1,350 exhibitors from 13 countries and regions.

### Fair Highlights

- Hall of Aurora
  - Residential Lighting
  - Technical Lighting
  - Horticultural Lighting
  - Smart Lighting & Solutions
  - Urban & Architectural Lighting
- ...and many more

### Shining a Light on Building

Dovetailing beautifully with Spring Lighting Fair is a  
**new zone in 2019 - Innobuild**

### More than a Marketplace

- Asian Lighting Forum
- Seminars and forums
- Networking Reception



## Hong Kong International Lighting Fair (Spring Edition)

6-9 April 2019

Hong Kong Convention and Exhibition Centre

Register Now for Your **FREE e-Badge**  
to Save HK\$100!

Web: [hklightingfaire.hktdc.com/ex/05](http://hklightingfaire.hktdc.com/ex/05)

Wap: [hktdc.com/wap/lightse/T119](http://hktdc.com/wap/lightse/T119)

App: HKTDC Marketplace



**First-time overseas buyers  
are entitled to exclusive  
travel incentive.**

**Pre-registration is required.**

Please contact HKTDC Office at Tel: (852) 2240 4065 or  
E-mail: [hklightingse.visitor@hktdc.org](mailto:hklightingse.visitor@hktdc.org) for details.



# LED Lighting Systems in Smart Buildings with DC Microgrids

While electric motors for ventilation and air-conditioning systems were already DC-based in the past, powerful IT systems, LED lighting systems, photovoltaic systems with batteries and charging systems for electro mobility are now increasingly being used in modern building environments. They all need direct current (DC). Therefore, an obvious step is to equip modern buildings with DC grids. Carsten Moellers from Abalight discusses a number of unresolved questions and presents possible solutions in this article.

The conditions of energy generation and its use in the context of modern buildings have been facing major change in recent years.

This development is being driven by increasingly decentralised energy generation and storage. Photovoltaic systems and batteries, as well as storage systems play an important role in this, as do fuel cells, all of which generate direct current (DC). On the demand side, the importance of DC appliances is increasing. While electric motors for ventilation and air-conditioning systems were DC-based in the past, powerful IT systems, LED lighting systems and, last but not least, charging systems for electromobility are now increasingly being used; these are all demands that are best supplied directly with direct current (DC).

Therefore, it is an obvious step to equip modern buildings with direct current grids and to save energy losses during the conversion from direct current to alternating current (AC) or

vice versa (DC-AC-DC). In recent years there have been various investigations [1], field trials and successfully realised projects in Europe, North America, Japan and China. The reduction of conversion losses and reactive power as well as a more efficient transmission have resulted in energetic savings of 5-10% [2], and even up to 30% depending on the application. In addition, direct current grids contribute to improvements in network quality (backlash due to harmonics) and enable genuine uninterrupted operation when switching to UPS systems.

In the course of these projects, however, a number of unresolved questions have emerged, in particular with regard to safety and protection concepts, not least as a result of the fact that over the past 100 years, empirical experience has been gained in dealing with alternating current grids in buildings, but less in dealing with direct current grids. The DKE German Commission for Electrical, Electronic & Information Technologies,

together with VDE and experts, has addressed these questions and summarized the corresponding recommendations for action and use cases for various applications in the German standardization roadmap for direct current in low-voltage grids (LVDC) [3].

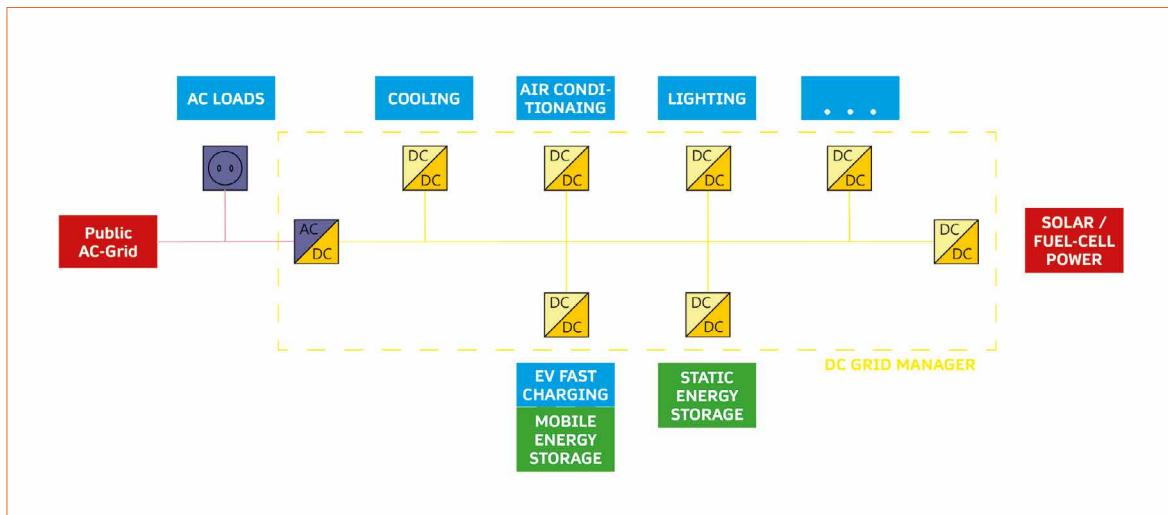

**Figure 1:**  
DC Microgrid example  
for a commercial  
building

## Smart Microgrids

Especially, in the self-use of renewable energies, there is a necessity to improve the coordination of energy generation and use of time- and intensity-variable consumers (Demand Side Management DSM). This is achieved by so-called Smart Microgrids, in which a central or decentralized control takes over load and storage management by means of IT-based communication. Such an infrastructure can also be used across the board for the Smart Building. With sensors and actuators, the Smart Building is able to react to changing environmental conditions and user needs.

The users increasingly arrive at the building by means of electric vehicles. Accumulators in these vehicles are also originally charged with DC. The acceptance of electromobility will largely depend on the charging infrastructure and charging times. Today, modern charging systems such as CCS (IEC 62196-3), CHAdeMo or Supercharger support fast charging with DC (so-called charge mode 4). The pertinent IEC standards provide for a current flow in both directions and corresponding bidirectional communication, enabling batteries in connected vehicles to help compensate for load fluctuations in the future (in the case of the Combined Charging System, this extended communication is mandatory according to ISO 15118).

What exactly could such a DC grid (DC microgrid) look like, for example, for commercial buildings (Figure 1)? Instead of equipping many devices with individual rectifiers, as is the case today, the alternating current grid is connected via a central rectifier with mains filter. The PV system, the battery storage system and the fast-charging system for E-mobility are then also connected to this DC grid. Different topologies can be used for this. Control can be provided via a DC grid manager.

## Established Voltage Standards

Since data centers have a large demand for direct current and the highest demands on network stability, they play a leading role in the development of standards (see also EMerge Alliance). For the first time, ETSI EN 300 132 3-2 defines a voltage range of 260 to 400 V DC for high power ranges. The standardization bodies and Europe, North America, Japan and China finally agreed on 380 V as the reference voltage for the distribution network in commercial buildings. The 380 V DC enable small line cross-sections and are compatible for the connection of regenerative energy sources, storage systems and charging systems for E-mobility. This standard has helped the industry to develop a wide range of components for the 380 V DC ecosystem.

The various loads can be connected directly to the 380 V DC distribution network or via a step-down DC-DC converter (see also IEC 61204-6) via a reduced voltage of 12, 24 or 48 V DC, for example. Such voltages are common in various industries such as aviation, railways, shipbuilding and vehicle construction where they have been tried and tested and standardized for many years. Since 48 V DC is still in the range of safety extra-low voltage and, compared to 12 or 24 V, enables smaller line cross-sections and lower line losses, this standard is not only establishing itself in the lighting sector and has been defined by IEC/SEG 4 as the preferred voltage level for low power ranges.

This article therefore further focuses on the application possibilities of the two preferred voltages of 380 V DC for the high and 48 V DC for the low power range in the lighting of commercially used buildings and does not address other voltages, such as 216 V DC for emergency power systems for switchable operation of 230 V AC (cf. DIN EN 50171).

## LVDC for Lighting Systems

First of all, it is obvious to supply the LED lighting systems used today directly with 380 V DC and then operate them with a step-down DC-DC converter, which reduces the maximum output voltage and generates the usually required constant current. The advantage of

**Figure 2:**  
A distribution and cabling example for a shop lighting project with a mix of linear luminaires for 380 V DC (blue) and track-mounted luminaires for 48 V DC

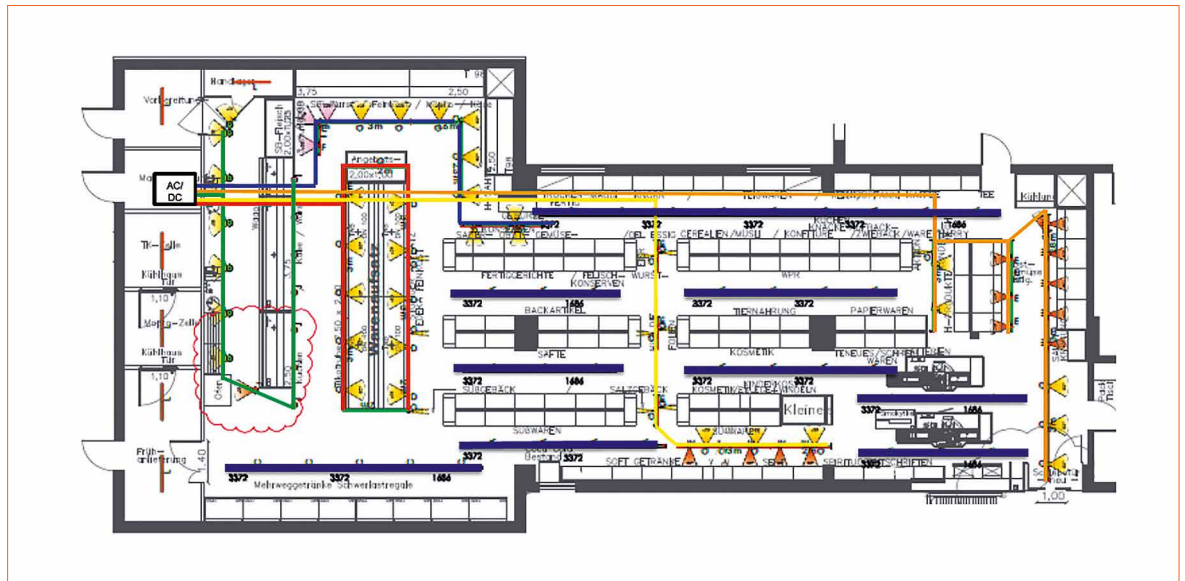

this approach is that it can transmit quite high powers with small line cross-sections to any light spot. The drawbacks are the high voltage up to each light spot and higher component costs at each light spot compared with converters for smaller input voltages. As the required power ratings of LED lighting systems become lower and lower compared to conventional light sources due to their high efficiency, the reference voltage of 48 V DC for lower loads is becoming increasingly important.

One approach for LVDC transmission is the Power over Ethernet (PoE) method based on IEEE 802.3. Here the data cable designed for Ethernet communication is used to simultaneously supply the loads (so-called Power Devices PD) with direct current via free or signal-carrying line pairs, as in this case the LED lighting system. PoE operates with a voltage range of 37-57 V DC depending on standard version and wire length, which means that it is not a 48 V DC network in the narrow sense. Feed-in takes place via so-called Power Sourcing Equipment (PSE), which, in turn, can be supplied via the 380 V DC distribution network.

The appeal of the PoE lies in its ability to map data communication with direct IP addressing and power supply in the same infrastructure.

The limitations of this approach derive from the fact that the transmittable power is extremely limited due to the small cable cross-sections and that relatively high power losses are incurred. In recent years, manufacturers and committees have increased the maximum power output of the PSE from 15.4 watts to up to 40 watts over two line pairs (Class 5) and from 60 to 100 watts over four line pairs (IEEE 802.3bt-2018). Nevertheless, the high power losses involved contradict the basic idea of more efficient energy transmission through direct current networks.

A highly promising third approach tries to compensate the disadvantages of the direct use of 380 V DC and PoE. The 380 V DC is transformed to 48 V DC at central points (Point of Load Conversion) and routed to the light points via sufficiently dimensioned lines, low-voltage tracks or energy rails. The constant current control of the LED luminaires can then be carried out via very compact DC-DC converters in the 48 V DC input. With sufficiently dimensioned line cross-sections, powers of up to 1 KW can be transmitted. This dimension fits quite well to a practical number of LED luminaires with typical power ratings. With regard to installation, it should be noted that the 48 V DC side operates within the safety extra-low voltage range.

At the same time, the extremely compact 48 V DC-DC converter meets the trend of miniaturization of LED luminaires. These converters are available as small independent boards that can be easily integrated into luminaires or adapters, or are already integrated on LED boards, e.g. for standardized ZHAGA formats (see also Vossloh-Schwabe or Tyco Electronics). Such converters can be designed without lifetime-critical electrolytic capacitors (drying out) of conventional switching power supplies, which significantly extend the maintenance cycles of the distributed light spots. In addition, the first COB concepts are being developed that can be operated directly with 48 V DC, for example via integrated linear regulators without additional DC-DC converters (see Osram ConVoLED). Due to the growing use of 48 V DC also in other applications, such as the on-board power supply of modern automobiles and electric vehicles (see VDA 320), a large number of corresponding components are available at low cost [4].

Practically, concepts can be used in which LED lighting systems with 380 V DC power supply, PoE and 48 V DC can be optionally combined. Figure 2 shows a project for shop lighting with a mix of linear luminaires for 380 V DC (blue) and track-mounted luminaires for 48 V DC.

## Smart Solutions for LVDC

However, this does not yet answer the question of how to control luminaires and communication, for example in combination with sensors, as represented by PoE (see above). There are basically three possible concepts for control and communication: communication via live DC lines (Power Line Communication (PLC)), communication via additional control lines (e.g. DALI) or radio-based communication (e.g. WiFi, ZigBee, Bluetooth, EnOcean).

PLC is only regulated in the frequency range from 3 to 148.5 KHz by the EN 50061-1 standard to protect against interference and ensure electromagnetic compatibility. Further standardization of this technology is lacking. Inevitably, as in other industries, only proprietary solutions such as Bits2Power or DC-String (Tridonic) have emerged in the lighting industry in conjunction with 48 V DC supply. In principle, these solutions are structured in such a way that a protocol such as DALI, which is received at the central converter for 48 V DC, is converted to a PLC signal and then communicates with the compact DC-DC converters of the individual luminaires. Currently these solutions do not support the supply of the central 48 V DC converter with 380 V DC input voltage but only with 230 V AC.

DALI has proven to be a digital standard (EN 62386) for line-based lighting control based on the Manchester protocol. Special features of the DALI bus are that the two DALI control lines require basic insulation and can therefore be laid together with the current-carrying 230 V AC cores in one cable, the DALI control line can supply power to sensors and actuators (max. 20 mA per consumer) and the system is protected against polarity reversal. The DALI bus itself operates with 250 mA and max. 22.5 V DC, but the DALI inputs must be designed for 230 V due to the risk of reverse polarity with conventional AC inputs. For the 48 V

DC supply concept, there are, for example, 4-pole busbars (see e.g. Eutrac Low Voltage) that permit DALI or other line-based communication such as 1-10 V or DMX. Corresponding compact DC-DC converters with additional DALI inputs are also available on the market. When implementing the solutions in combination with 48 V DC, it is important to note that the input of the compact DC-DC converters is generally not designed for higher voltages, which could principally be looped through via the DALI bus in the event of reverse polarity.

In recent years, radio-based communication standards for lighting management systems (LMS) and the Internet of Things (IoT) have become increasingly popular. In addition to WiFi (IEEE 802.11), these are mainly low-power standards such as Thread or ZigBee or ZigBee Green (IEEE 802.15.4), Bluetooth (IEEE 802.15.1) and EnOcean (IEC 14543-3-10). Wireless solutions of this kind complement a basic 48 V DC supply very easily with lighting control and sensors.

EnOcean and ZigBee Green even allow Micro Energy Harvesting (MEH), eliminating the need for switch actuators to be powered and allowing them to be placed wirelessly.

Since radio-based solutions are already finding their way into Smart Buildings, they can be used for comprehensive event-based building automation at the field level. Typically, the different systems at the field level are then merged via an IP backbone (e.g. BACnet-IP) at the automation level (BACnet explicitly stipulates the ZigBee protocol as the communication layer at the field level). The management level can be mapped via BACnet (see DIN EN ISO 16484-5), via other building management standards such as oBIX or via the general automation standard OPC-UA (IEC 62541).

## Challenges

Despite their many advantages, DC systems also present challenges that should not remain unmentioned. These include, in particular, technical challenges and still underdeveloped standardization. Both topics are closely linked, since the industry can only reliably address some technical challenges once certain gaps in standardization have been closed or contradictions eliminated.

The greatest technical challenge is the danger of arcing due to the lack of zero crossing of the DC voltage. This danger occurs in particular when pulling a plug under load, during switching and in the event of insulation faults. From a voltage of around 20 volts, the arc is no longer self-extinguishing. As a result, circuit breakers, cables, switches and plugs must meet special requirements. For this reason, connections without special precautions or conditions may only be disconnected without load resp. currentlessly plugged. The cables and conductors should be separately color-coded. For example, the new IEC 60445:2018 stipulates red for the positive outer conductor, white for the negative outer conductor and pink for the functional grounding conductor.

Studies on corresponding faults show that the vast majority of arc faults are due to faults in the grounding concept (cf. IEEE Std 493-2007). Therefore, the grounding concept is of particular importance in the context of direct current systems. ETSI EN 301 605 describes two permissible grounding concepts for direct current systems: the IT system and the TN-S system.

At LVDC, the TN-S system operates with an earthed minus to the central grounding point (CGP) and protection is normally provided by the switch-off conditions of the overcurrent protection devices, unless there is a comparatively complex residual current monitoring RCM (according to DIN EN 62020).

Therefore, the TN-S system without residual current monitoring is only used in applications where system availability requirements are not particularly high.

Conversely, in the IT system, the first error is only reported by the Insulation Monitoring Device IMD (DIN EN 61557-8). Only then is grounding produced as in the TN-S system, whereby the so-called High Resistance Midpoint Grounding HRMG is preferred for direct current systems. This means that the IT system can continue to operate safely after the first fault has occurred, which is particularly favorable, for example, in IT, the process industry or railways. Electro-mechanical all-pole switches have proven highly effective for the IT system in conjunction with LVDC.

As far as standardization is concerned, it should be pointed out that there are specific standards for a large number of DC applications, which, however, are not designed for building installation. In principle, the construction of DC networks is covered by DIN EN 60364, but there is a lack of concrete LVDC standards for insulation measurement, connectors and switches. In some cases, contradictions among individual standards, e.g. for the assessment of clearance distances between the basic standard DIN EN 60664 and the cable, connector and device standards, must be harmonized.

Until these standards are revised, special attention must be paid to the selection of suitable components for LVDC. With the increasing number of ambitious projects implemented with renowned partners, best-practice solutions have developed which can be used as a basis for orientation. Finally, due to their limited experience with LVDC, electrical specialists should receive special training. For example, NFPA 70E already included special requirements for handling DC systems > 100 V in 2012.

## Outlook

The European Union has recognized both the limited availability of fossil fuel resources and the dangers posed to our civilization from the CO<sub>2</sub> induced greenhouse effect. Since renewable energy sources are comparatively expensive, the silver bullet lies in increasing energy efficiency. It meets this requirement with the 2010/31/EU Directive (Energy Performance of Buildings EPBD) in the area of standards for new buildings and thus prescribes Nearly Zero Energy Building (NZEB) from 2021.

In the course of the amendment EPBD 2018 (2018/844/EU) further objectives were also set for the energetic restoration of existing buildings, the intelligence of technical building systems to adapt to user requirements and optimize overall efficiency and the provision of charging infrastructure for electro mobility.

LED lighting systems already contribute to saving energy and improving the CO<sub>2</sub> balance. Further potential savings can be exploited in the future primarily through systemic optimization of commercially used buildings.

In this article it has been shown that direct current systems in the low voltage range (LVDC) offer a considerable savings potential in the context of systemic optimization and have a large number of additional advantages. Semiconductor-based LED lighting systems operate with direct current by definition - as do an increasing number of other loads - which makes them ideal for being supplied with LVDC.

In addition, LVDC can be used to better emphasize the actual advantages of LEDs, such as miniaturization and long service life, by eliminating some life-critical components for AC-DC conversion. This opens up degrees of freedom in the design of LED luminaires and extends their maintenance cycles.

With the integration of smart IoT solutions, the LED luminaires can be used to determine real-time location-based data using a wide variety of sensors. LED luminaires can be ideally combined with sensors, as they are typically placed in locations suitable for sensors while the LEDs are DC-powered anyway. The data obtained can be used for a variety of purposes such as energy optimization, simplification of facility management, individualization of lighting portfolio, management of resources or improvement of the user experience in a building (Indoor Location Services).

In addition to the integration of renewable energies and storage systems as well as charging systems for electric mobility, LVDC offers another advantage: the solution contributes to improving grid stability. This aspect should not be underestimated, considering the increasing problems with the contamination of AC grids.

Given this background, an increased use of LVDC systems together with LED lighting solutions in commercial buildings should be observed in the coming years, both as pure LVDC solutions and in the form of hybrid DC/AC solutions. Data centers will only likely to have played a pioneering role in this.

This development is likely to be promoted both by the current achievement of the economic efficiency of internal consumption of electricity from new PV systems without subsidies and by the internal consumption of electricity from existing systems where EEG subsidies in Germany expire for the first time in 2020.

LVDC not only promises potential savings when it comes to supplying buildings. Since similar savings potentials can be exploited in industrial applications (70% of industrial electricity consumption is accounted for by electric motors) [5], this technology is expected to be used in numerous industries.



Together with progress in standardization it will stimulate a broader range of respective components.

Last but not least, DC microgrids not only benefit the highly developed industrialized countries, but also enable the autonomous

electrification of underdeveloped rural regions, for example in conjunction with cheaper batteries and PV systems. ■

#### References:

- [1] B. Wunder, 380 V DC in Commercial Buildings and Offices, Fraunhofer, 2013
- [2] U. Boeke, M. Wendt, DC-Power Grids for Buildings, IEEE, 2015
- [3] Deutsche Normungs-Roadmap Gleichstrom im Niederspannungsbereich, DKE/VDE, 2016
- [4] 48-Volt-Bordnetz - Schlüsseltechnologie auf dem Weg zur Elektromobilität, ZVEI, 2015
- [5] Forschungsprojekt DC-INDUSTRIE Gleichspannungsnetze in der industriellen Produktion, ZVEI, 2017

Photography by Nacása & Partners

## The Synergy of *Light in Life*

The connected future is yours to discover at **LIGHTFAIR® International 2019**: the lighting and design industry's source for all that is new and next. Where brilliant solutions in lighting, connectivity, design and integration will unfold in a synergy of light in life. In the unsurpassed resources of the world's largest annual architectural and commercial lighting event.

**LIGHTFAIR**

INTERNATIONAL

The future. Illuminated.

**2019**

REGISTER NOW  
LIGHTFAIR.COM



IALD



# Technologies for Shared Office Space

Shared office spaces are gaining popularity as a flexible, resource-efficient and creativity-inspiring way to work. The dynamic nature of such office spaces requires building automation and lighting control solutions that can quickly be deployed and easily be adapted to new office layouts.

Matthias Kassner, Vice President Product Marketing at EnOcean GmbH, takes a look at different connectivity architectures (wired, wireless, hybrid) and protocols (Bluetooth, ZigBee, EnOcean, PoE) to assess their usability and show how minimizing the need for maintenance is a key for increasing profitability of service-based offerings.

An average of 50% of the available space in a typical office building remains unoccupied over the course of a business day. At the same time, space in cities is getting very short and incredibly expensive. To counter this trend, services for shared office space are becoming more and more popular. Beside flexible and adaptable room layouts, there is a need for data infrastructures that enable demand-based intelligent control of all building areas. Thereby, not all technologies are equally suitable for solving the requirements of such an agile concept.

Co-working has had a major impact on the performance and utilization of commercial real estate. It has been responsible for a significant amount of positive net absorption in major metropolitan markets enabled by additional investments into upgrades and expansions of amenities in existing buildings. From humble beginnings in 2007 with just 14 of such spaces in operation, it was estimated that during 2018 more than 600,000 people would be working in 4,500

co-working spaces in the US alone. The worldwide number of such spaces was expected to top 15,000 by the end of 2018 [1].

Several key drivers have enabled this development: easy access to office space within the desired geography, the wish for flexible working environments that can be easily adapted to the changing number of employees and the desire to co-work within an open, creative atmosphere that stimulates exchange with other people. This has been accelerated by a trend towards larger co-working spaces (with over 100,000 square feet of area\*) that are targeting established companies. By offering office space in target locations with technological resources and talent, they can stay in tune with developing industry trends and changing demands in resources.

Addressing the requirements of such a diverse customer base is possible only with highly flexible architectures enabling different usage scenarios and easy reconfiguration.

Workspaces need to be resizable and reconfigurable (open, semi-open, fully enclosed) while open collective spaces invite social and professional interaction between users, enabling occasional, recurrent, and daily meetings as well as special events.

In short agile working models require agile buildings.

### Agile Buildings Tasks

Agile buildings enabling shared office spaces have to provide a number of key features an architecture and technical area (building, lighting, HVAC, controls) suited for user convenience with the option for constant reconfiguration, an IT and data infrastructure enabling data analytics to monitor and optimize key performance figures and a service offering (administration, access control, supplies, cleaning etc.) that meets the needs of all involved in a financially efficient way.

User convenience is defined by a wide range of factors including the neighborhood in which the building is located, the internal layout of work and open spaces and the interior design. All of this combined shall create an inviting atmosphere for work and collaboration. Specifically for controls, the individual adjustment of workplace lighting according to user preference is one of the most relevant requirements. Some buildings might additionally allow the control of window blinds and even heating and ventilation by the user, but this is generally an exception.

Constant reconfiguration means that installation cables and equipment into fixed positions should be minimized and as much infrastructure as possible should be placed into the ceiling to minimize obstruction of the floor layout. Data analytics require a flexible sensor infrastructure capable of monitoring key parameters such as desk/space utilization, supply level tracking (e.g. soap and towel dispensers) and demand-based cleaning in consideration of activity and utilization.

Finally, the results generated by these data analytics have to be easily usable within service models both of the building operator (e.g. space utilization monitoring) and external service companies (e.g. cleaning and catering).

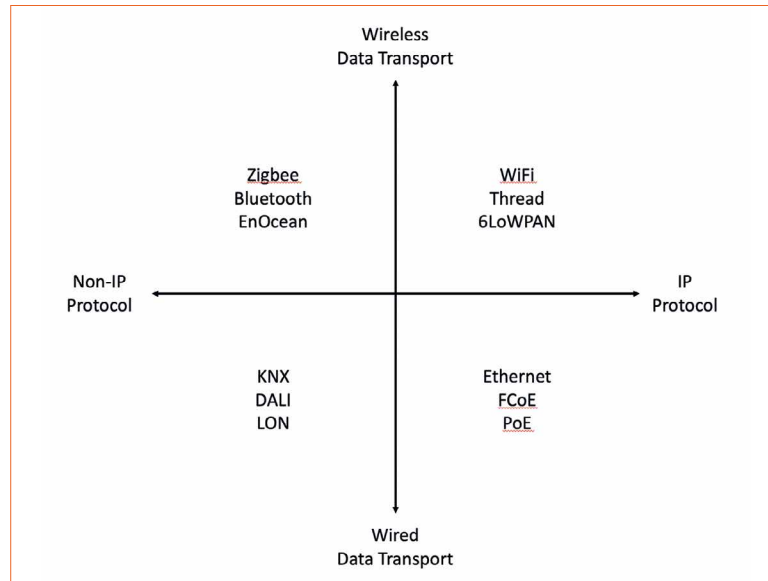

**Figure 1:** Classification chart by the transport medium (cable versus wireless) and the use of IP protocol

### New Service Models

Agile environments with changing requirements benefit from service models where non-core activities such as cleaning and catering are outsourced. Only a minority of companies today still employ their own staff for such tasks. Similar trends start to become visible in the building infrastructure as well.

Taking the case of lighting, the benefits of the transition from conventional to LED lighting have enabled new business models where third parties become partly or fully responsible for the operation of the lighting system. Energy service companies (ESCO) that traditionally have focused on the execution of energy saving projects such as lighting upgrades are increasingly offering financing methods where a part of the energy cost saving for the customer is used to pay the project cost.

Under this model, an ESCO will perform an initial analysis of the property and its energy consumption and then design, install and maintain a more energy efficient solution. The saved energy cost will be used to pay back the capital investment of the project over an agreed period of time ranging from five to twenty years. If the return on investment is insufficient then the ESCO is usually required to pay the difference.

Taking this model further, Lighting as a Service (LaaS) is a service delivery model in which light is delivered to the customer according to his requirements and charged on a subscription basis rather than via a one-time payment.

What both models have in common is that the provider is responsible not only for the initial installation of the lighting system but also for its operation. Operational expenses thereby become a critical factor for the return of investment (ROI). The goal of optimizing operation expenses drives a strong demand for data insight allowing for automatic control of building parameters such as light levels based on occupancy and available light or to schedule tasks such as cleaning based on actual utilization rather than fixed schedules. It also requires minimizing maintenance work which will be an important aspect when discussing wireless solutions.

### Data Infrastructures for Agile Buildings

Data is the basis of agile buildings. It comes in many forms it can represent user requests (e.g. setting a light level), allow information exchange (e.g. Internet connection) and monitor key parameters (e.g. occupancy).

Exchanging data requires a suitable infrastructure meeting specific requirements regarding the amount of data (speed, volume) to be exchanged, the distance between the partners exchanging the data, the transport medium (wire, fiber, air) and the available power. In an ideal scenario, one infrastructure would cover all those requirements. This, however, is usually not possible. A look at different available technologies explains why.

#### Pros and cons of different available technologies:

- Fiber, Ethernet or copper cables are ideal mediums to transport large amounts of data throughout a whole building with minimum latency and highest reliability. Their flexibility, however, is very limited as they require the installation of dedicated cabling.
- WiFi on the other hand is an ideal choice for exchanging large amounts of data over limited distances with greater flexibility. However, its power consumption makes it not well-suited for wireless controls and sensors.
- Dedicated low power wireless protocols such as Zigbee, Bluetooth® or EnOcean, on the other hand, combine very low power consumption with wireless flexibility. They can, however, not be used to transport large amounts of data or cover entire buildings.

Data infrastructures within a building are therefore, by nature, usually hybrids which can be classified by their transport medium (cable versus wireless) and their use of IP protocol as shown in the following graph (Figure 1).

#### Wired Versus Wireless Data Transport

Wired solutions can combine high communication reliability with high data transport capacity over larger distances making them an ideal choice as data backbone within a building. Ethernet (standardized within the IEEE 802.3 family) is increasingly becoming the

standard choice for this application. Historically, wired connections have been used for all applications even without the need for large data rates. DALI using a data rate of just 1,200 bit per second is a typical example of that.

The key disadvantage of a wired data infrastructure is its inherent inflexibility. Its need for dedicated wiring makes quick reconfiguration difficult. Simple tasks such as moving a light switch to a different location requires significant construction work. This is not an option for agile buildings. Therefore, wireless solutions have become increasingly attractive as a complement to the wired infrastructure.

One key challenge when moving to truly wireless solutions (without power cables) is the question of how to provide power to these devices. Batteries have been widely used and continue to be an attractive proposition for cases where initial cost is the prime concern and maintenance for battery exchange is no concern.

#### Maintenance A Question of Power Source

The impact of maintenance becomes quickly obvious in larger buildings where thousands of sensors are distributed over several floors and offices. Often these devices are mounted unobtrusively in places that are difficult to reach, e.g. on or above drop ceilings. In these cases, battery exchange is a challenging and time consuming effort.

Energy harvesting technology has meanwhile established a reliable alternative to batteries as an energy source for wireless devices. Self-powered sensors gain all energy needed for their operation from the surrounding environment. The most obvious example is the energy harvesting wireless switch that generates its energy from the kinetic movement of being pressed. Other sources used for

self-powered sensors are light (indoor and outdoor) or temperature differences to detect occupancy, light intensity, temperature, humidity, access or even acceleration; to name a few.

Energy harvesting devices, by their nature, do not require maintenance and can therefore have a positive impact on total cost and operation effort. It also gives installations with energy saving purposes an eco-friendly character by avoiding tons of battery waste. Energy harvesting technology can today support a variety of different low power wireless protocols such as Bluetooth® Low Energy (BLE), Zigbee PRO Green Power and EnOcean sub 1 GHz radio that can complement the IP infrastructure of a building.

#### IP Versus the Rest of the World

When looking at protocols, an infrastructure communicating from end to end, purely based on IP (Internet Protocol), offers significant advantages. Almost every commercial building today needs an IP infrastructure (Ethernet, WiFi or both). Extending this towards sensors and controls would eliminate the need for dedicated gateways translating between different protocols. IP-based lighting control could thereby directly integrate into the IP infrastructure and become much easier to monitor and administrate.

#### Power over Ethernet

Power over Ethernet (PoE) is an example of a wired implementation of an all IP infrastructure. The key function of PoE is the elimination of additional cabling whenever a PoE-connected device can be supplied directly via the Ethernet cable. Products such as conference phones and IP security cameras are ideal examples of solutions well-suited for PoE.

More recently, PoE has also been proposed for the lighting infrastructure



ASEAN's Largest Show on  
LED Technology & Lighting Solutions

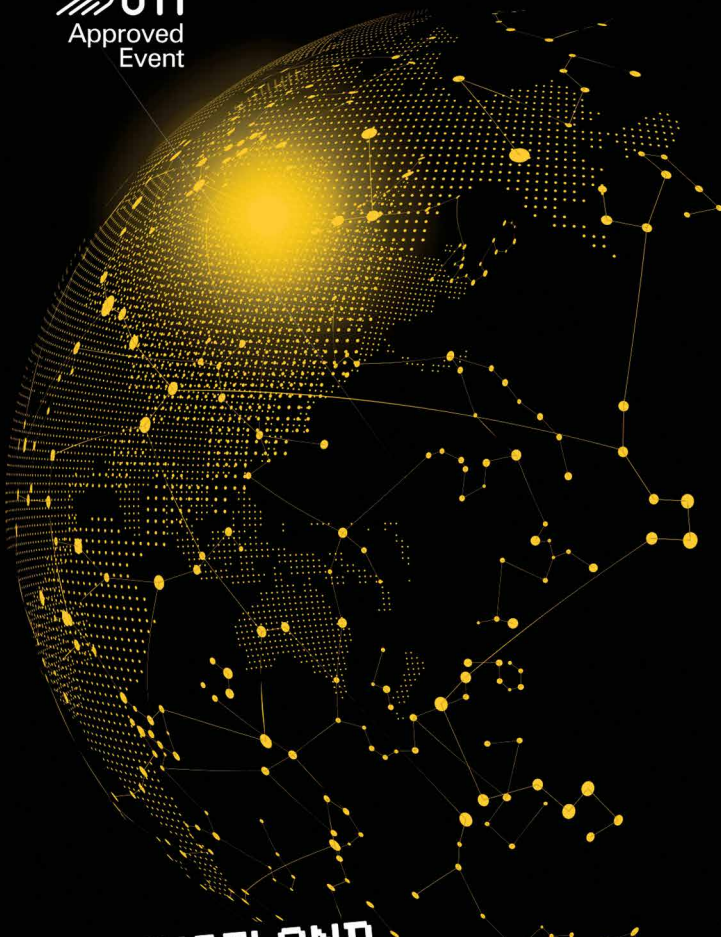

# Solutions Beyond Illumination

THAILAND

**LED**  
**EXPO 2019**

+



**LIGHT**  
**ASEAN**

**27-29 JUNE, 2019**

**Hall 7-8**

**IMPACT Exhibition & Convention Center, Bangkok, Thailand**

**[www.ledexpo-thailand.com](http://www.ledexpo-thailand.com)**

## ORGANIZERS



**MEX Exhibitions Pvt. Ltd.**

9 LGF, Sant Nagar, East of Kailash, New Delhi-110065, India

**Ms. Himani Gulati** Tel : +91-9312285142

E-mail: [himani@mexexhibits.com](mailto:himani@mexexhibits.com)

**Mr. Gaurav Juneja** Tel : +91-9810301644

E-mail: [gaurav@mexexhibits.com](mailto:gaurav@mexexhibits.com)



**IMPACT Exhibition Management Co., Ltd.**

Bangkok Land Building, 10 Floor, 47/569-576, Moo 3, Popular 3 Road,  
Banmai Sub-district, Pakkred District, Nonthaburi 11120

**Wishjanond Vichaiyuth**, E-mail: [wishjanondv@impact.co.th](mailto:wishjanondv@impact.co.th)

**Figure 2:** The example for an IPv6 data packet demonstrates the data overhead from the source and destination address

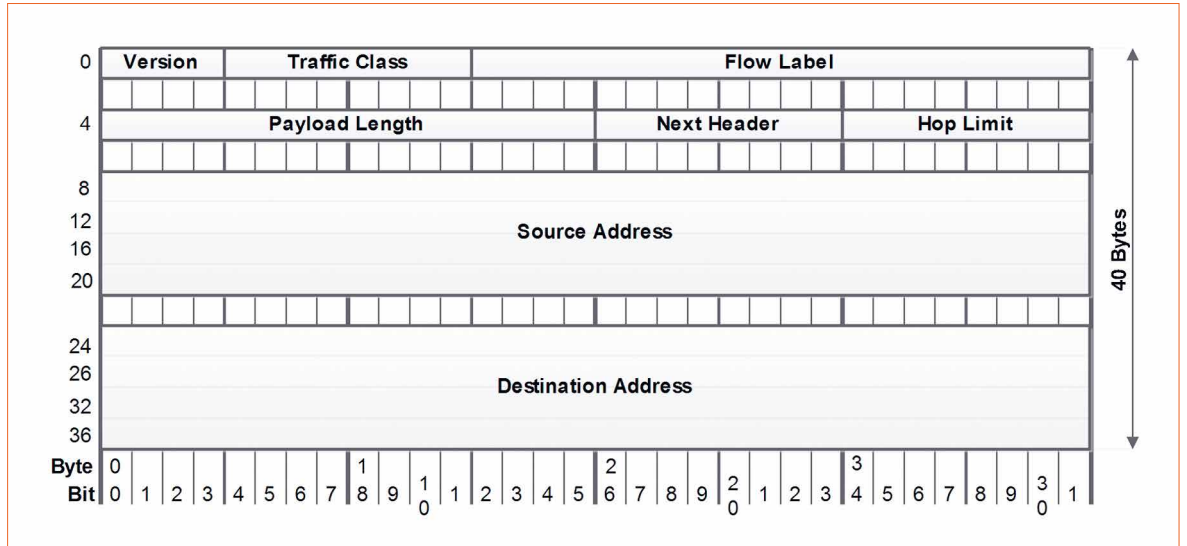

**Figure 3:** 6lowPAN integration structure within Thread

in buildings. The key challenge there is that Ethernet cabling is optimized to transport vast amounts of data and limited amounts of power. Ethernet cabling is capable of sustaining data rates that can exceed 1 Gigabit per second while lighting control requires comparatively little data the well-known DALI protocol, for instance, operates at just 1,200 Bit per second.

Power delivery, on the other hand, is limited in PoE systems by the resistance of the wires within the Ethernet cable. This resistance generates heat and results in voltage drops proportional to the length of the cable. High quality cabling and special Ethernet switches have to be used to maximize power delivery within lighting systems.

PoE also does not meet the mobility requirement of sensors and switches within agile buildings. Having to connect such devices via Ethernet cable makes quick space reconfiguration very difficult. IP infrastructures are therefore usually augmented with other (typically low power) wireless solutions to provide connectivity to devices within the office environment.

**WiFi**

WiFi would seem to be the obvious answer for that; however due to the protocol overhead combined with the high power requirements it is not

well-suited for this task. The header structure of an IP packet (IPv6) illustrates the point (Figure 2). Here, source and destination address alone add 32 byte of overhead.

Additional requirements such as certificate-based security schemes will further increase that discrepancy. Most IP-based wireless protocols therefore aim to reduce the overhead of IPv6 protocol in the wireless communication.

**6lowPAN**

6lowPAN has become a common choice for such protocols and has gained a lot of attention recently due to its integration within Thread. 6lowPAN provides IP communication on top of IEEE 802.15.4 (which is also used in Zigbee) as shown in the following illustration (Figure 3).

This approach combines the benefits of an IP-based communication model with those of a protocol optimized for wireless communication. One immediate disadvantage is that dedicated gateways between Ethernet-based infrastructure and 6lowPAN/Thread are required.

**EnOcean**

Considering the fact that wireless protocols will need gateways anyway, another approach has been to cover larger distances with minimal energy to enable the longest possible operation time for

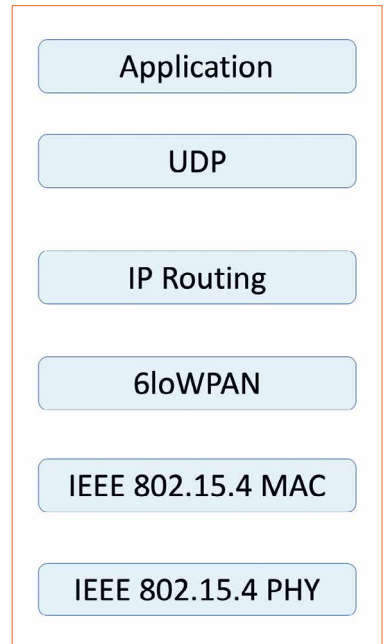

sensors and controls. The most prominent example of such wireless protocols dedicated to building automation and lighting control is the international EnOcean standard (ISO/IEC 14543-3-1X), which is supported worldwide by more than 400 member companies.

While many protocols such as Bluetooth®, WiFi and Zigbee operate in the 2.4 GHz frequency band, this protocol uses the sub 1 GHz radio bands. This provides the advantage of much higher communication distances for a given transmission power due to lower signal attenuation.

This attenuation (path loss) increases for a given distance

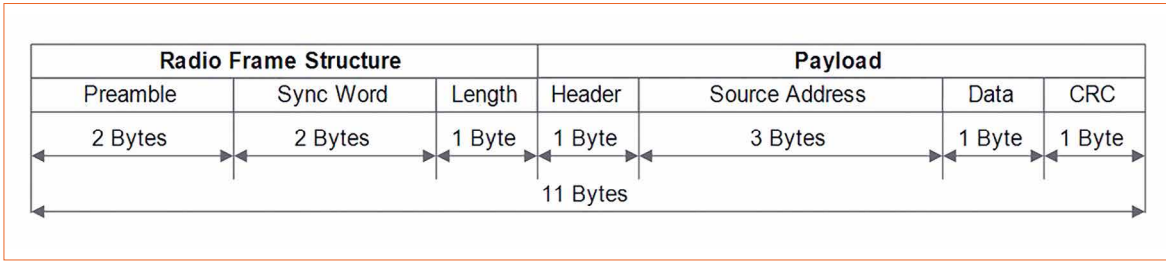

**Figure 4:** Data string structure of the EnOcean wireless protocol

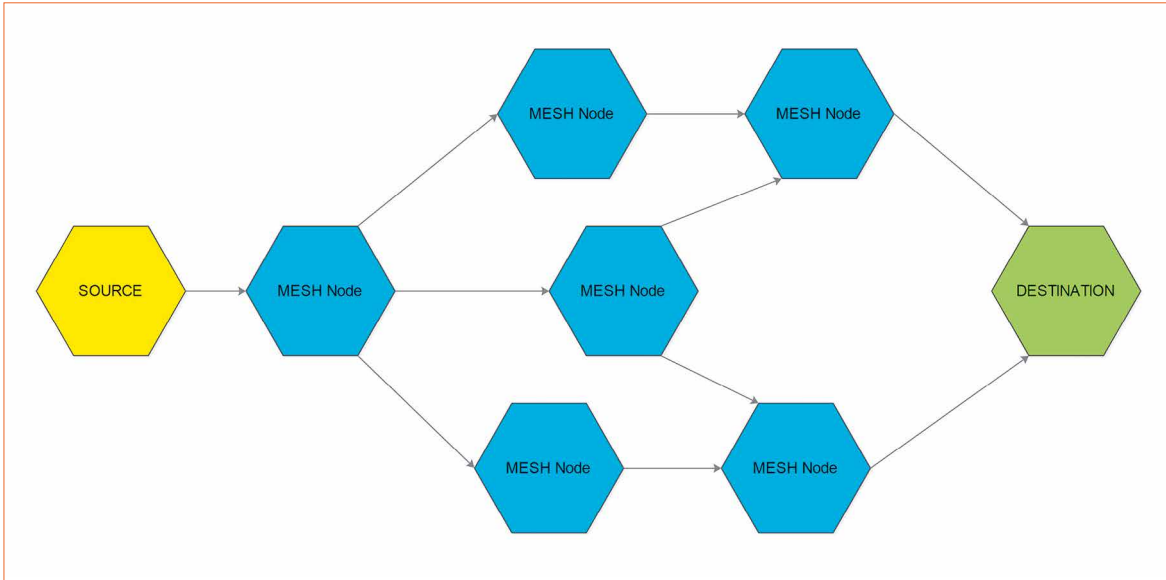

**Figure 5:** Schematic for a Bluetooth Mesh network structure

directly with the frequency according to the following formula:

$$Path\ Loss = 20 \cdot \log_{10} \frac{4 \cdot \pi \cdot d \cdot f}{c}$$

The use of lower frequencies therefore provides much better coverage for a given transmission power and is thus optimal for protocols targeting lowest energy consumption. Combining this with highly compressed data frames, as shown in the graph (Figure 4), makes it possible to create fully self-powered (energy harvesting) devices.

**Bluetooth®**

Another common requirement is the ability to directly interact with the wireless devices using smartphones and tablets. Almost all such devices include Bluetooth® functionality, which has become an attractive option, especially with its Bluetooth® Low Energy (BLE or Bluetooth® Smart) extension.

The history of the Bluetooth® radio standard dates back to 1994 when

a number of companies looked for a mechanism to replace wired connections. In that year, Ericsson proposed the concept of a wireless connection that could replace the common RS-232 cables used for communication between different devices.

In parallel to that, companies such as Nokia, Intel, IBM and Toshiba were also investigating mechanisms to wirelessly connect devices such as cellphones and computers. These five companies formed a special interest group (SIG) which was officially established in 1998.

In June 2007, Bluetooth® SIG acquired the Wibree Alliance, a Nokia-led initiative that had developed an ultra-low power (ULP) form of wireless connectivity using much less power than the existing Bluetooth® wireless technology that could be used for communication between cellphones and accessories. Beginning with Bluetooth® version 4 (released in 2009) this feature now called Bluetooth® Low Energy has become part of the standard Bluetooth® stack.

The recent introduction of a mesh network topology where messages can be relayed from the source to the destination via intermediary devices has greatly extended the communication range of Bluetooth® systems allowing coverage of larger areas with a Bluetooth® Mesh network (Figure 5).

The combination of classic Bluetooth® for communication with smartphones and audio accessories, Bluetooth® Low Energy for communication with sensors and other low power devices and a mesh network topology for covering larger areas makes Bluetooth® protocol a very compelling choice as low power data network. Deploying Bluetooth® mesh within the lighting system therefore provides the infrastructure for sensor data within buildings.

**Minimizing Infrastructure Upgrades**

The need for upgrading the building network infrastructure to support new data-driven services provides a significant barrier. In many

environments such upgrades will create detrimental business disruption which might be difficult to justify. Different schemes have therefore been proposed to minimize such disruption by reusing the existing infrastructure. One promising approach is the upgrade of WiFi access points to be able to capture data from low power wireless devices.

Aruba Networks (an HP Enterprise company) is one of the leading providers of network infrastructure such as wireless access points. Aruba ships millions of indoor and outdoor Wi-Fi access points every year for smart home, retail, healthcare, hospitality, education, service provider, enterprise, industrial, manufacturing, airline, and government customers. With their latest software release, Aruba access points can use their built-in BLE radio to receive sensor data from EnOcean's energy harvesting Easyfit Bluetooth® sensors and switches and forward those into the enterprise network.

The ease with which self-powered BLE devices can be added to an Aruba network without the need for new IT hardware or costly installation work makes the solution very compelling for customers.

**Paradigms of Tomorrow**

Future agile buildings enabling highly flexible co-working and co-utilization space will require large amounts of sensor data to continuously analyze and optimize usage and operation. This data forms the basis for new service models that will augment or replace existing building operation paradigms.

Creating, capturing and delivering such data requires a flexible network infrastructure that can continuously adapt to new usage scenarios. In most cases such infrastructure will be a mix between IP backbone systems (Ethernet + WiFi) and dedicated low power wireless protocols.

The upgrade of lighting systems towards larger area wireless mesh networks creates a unique opportunity for a high density, low power data network encompassing the entire building. As an intermediate step, reuse of existing IT infrastructure such as wireless access points can enable quick initial deployment without the need for major upgrades.

Operation and maintenance cost continues to be a key factor for the total return on investment. Under many service models this cost has to be covered by the operator thus driving a strong need for minimizing them. Energy harvesting wireless solutions are ideally suited for such cases. They are therefore a key ingredient to providing the flexible building-level intelligence without maintenance for the agile building of tomorrow. ■

**References:**

- [1] gcuc and Emergent Research: "Number of U.S. and Global Coworking Spaces and Members 2017-2022 (December, 2017 Forecast)" <http://gcuc.co/wp-content/uploads/2017/12/GCUC-Global-Coworking-Stats-2017-2022.pdf>

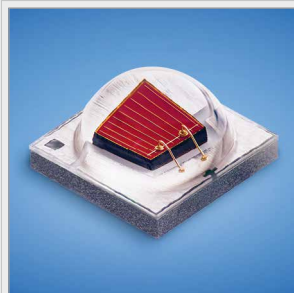

**Cree® Delivers Best-in-Class Horticulture Efficiency with New Red XLamp® XP-E2 LEDs**

Cree announces the new XLamp XP-E2 Photo Red and Far Red LEDs that deliver breakthrough performance for horticulture applications. The new Red XP-E2 LEDs are a drop-in upgrade for existing XP-based designs that outperform competing LEDs by up to 68%. These higher performance LEDs increase the efficiency of LED luminaires and make it more affordable to grow food under optimized lighting.

To learn more, please visit [www.cree.com/xlamp-xp-e2?WT.mc\\_id=crx1710](http://www.cree.com/xlamp-xp-e2?WT.mc_id=crx1710)

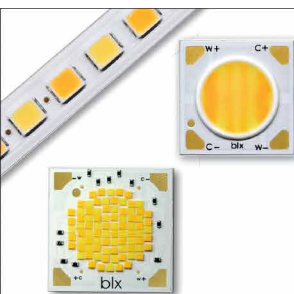

**Vesta® Series Human Centric Solutions**

The industry's broadest portfolio of Dim-To-Warm and Tunable White arrays & modules

**Features across the family include:**

- Color tuning range options from 2700K-5000K and 2700K-6500K
- Six different array LES sizes ranging from 9-29mm delivering up to 10,000 lumens
- Phosphor dispensed and chip-scale-package options
- Inline tunable white modules for edge lit applications



[bridgelux.com](http://bridgelux.com)



# guangzhou international lighting exhibition

# 24<sup>th</sup>

The most influential and comprehensive lighting  
and LED event in Asia

## 9 – 12 June 2019

China Import and Export Fair Complex  
Guangzhou, China

[www.light.messefrankfurt.com.cn](http://www.light.messefrankfurt.com.cn)

### Contact

Messe Frankfurt (HK) Ltd

Tel: +852 2238 9969

Fax: +852 2519 6079

[light@china.messefrankfurt.com](mailto:light@china.messefrankfurt.com)



光亞 · Guang ya



messe frankfurt



## LED professional Review (LpR) - Annual Subscriptions

### LpR Digital Magazine

- 6 issues
- pdf download
- high resolution pictures and graphs
- printable
- commercial use
- access to all previous issues
- Euro 78.80

### LpR Printed Magazine

- 6 issues
- Euro 158.40

<http://www.led-professional.com/subscription>

## Cover-page

Artwork: Thomas Klobassa,  
©LED professional 2019

Main Image: Arno Grabher-Meyer,  
LED professional

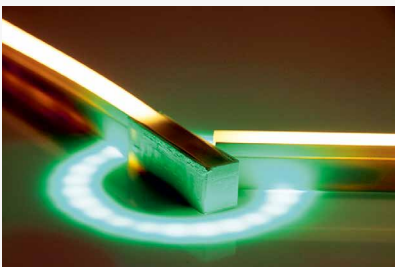

**Bilton's inductive coupled flexible linear module was on display at LpS 2018 in Bregenz**

## Next LpR

### DISRUPTIVE TECHNOLOGIES Issue 73 - May/June 2019

#### TECH-TALKS BREGENZ

Julian Carey, Product & Technical Marketing Manager, SLD Laser

Julian Carey, Product and Technical Marketing Manager at SLD Laser attended LpS 2018 in Bregenz. LaserLight had recently demonstrated record-breaking results with 750 lumens emitted from a 300 micron diameter window, which was a good reason to talk to him about the status quo of laser technology, which applications are currently applicable, SLD Laser's strategies and goals, and the future prospects for this technology. ■

#### RESEARCH

##### "Best Papers" at LpS 2018: Hermetic Polymer-Free White LEDs for Harsh Environments

AlGaInN-based white LED can achieve lifetimes of up to 100,000 h depending on junction temperature and current density. However, state of the art silicone encapsulated LEDs with powder-based phosphors reveal a strong dependence of field lifetimes on environmental conditions such as humidity, corrosive gas and air pollutant exposure. An interesting alternative to polymer-dispersed phosphors are luminescent ceramics. The article explains how they can be used as a hermetic, light converting cap material. Further properties and the advantage of completely avoiding polymers are also discussed. ■

#### TECHNOLOGIES

##### AI - Today and Tomorrow

Recently, Artificial Intelligence has emerged as an evolutionary force in almost every industry, demonstrating its potential to radically change existing processes. In common literature, AI is interchangeably used with Machine Learning, for which various tools have become commonplace. The author discusses AI in the context of the lighting industry where the scope of applications of AI is similarly quite broad, impacting the various stages involved in the lighting life cycle such as design, installation, commissioning and configuration. ■

##### LiFi as a Paradigm-Shifting 5G Technology

There are many misconceptions about LiFi, a wireless communication technology that uses the infrared and visible light spectrum for high speed data communication. The authors will explain what Light-Fidelity (LiFi) is and argue why it is a 5th Generation (5G) technology. Peak transmission speeds of 8 Gbps from a single light source have been demonstrated, and complete cellular networks based on LiFi have been created. Besides discussing numerous misconceptions, the potential impact this technology can have across a number of existing and emerging industries will be explained as well as new applications that LiFi can unlock in the future. ■

subject to change

## Imprint

LED professional Review (LpR), ISSN 1993-890X

### Publishing Company

#### Luger Research e.U.

Institute for Innovation & Technology  
Moosmahnstrasse 30  
A 6850 Dornbirn, Austria / Europe  
phone +43 5572 39 44 89  
fax +43 5572 20 60 70  
[info\(at\)lugerresearch.com](mailto:info(at)lugerresearch.com)  
[www.lugerresearch.com](http://www.lugerresearch.com)

#### Publisher

Siegfried Luger +43 699 11 33 55 70  
[s.luger\(at\)led-professional.com](mailto:s.luger(at)led-professional.com)

#### Editor-in-Chief

Arno Grabher-Meyer +43 699 11 33 55 18  
[a.g-m\(at\)led-professional.com](mailto:a.g-m(at)led-professional.com)

#### Int. Account Manager

Theresa Koenig +43 699 11 33 55 20  
[theresa.koenig\(at\)led-professional.com](mailto:theresa.koenig(at)led-professional.com)

#### MarCom Manager

Bronwen Rolls +44 797 401 2962  
[bronwen.rolls\(at\)led-professional.com](mailto:bronwen.rolls(at)led-professional.com)

### Your Sales Contacts

#### Int. Sales Manager

Brigitte Lindner +43 699 11 33 55 19  
[brigitte.lindner\(at\)led-professional.com](mailto:brigitte.lindner(at)led-professional.com)

#### China, Hong-Kong

Lolo Yeung +852 9732 2081  
[lolo\(at\)castintl.com](mailto:lolo(at)castintl.com)

#### Germany

Armin Wezel +49 30 526 891 92  
[armin\(at\)eurokom-media.de](mailto:armin(at)eurokom-media.de)

#### India

Priyanka Rai +91 124 478 7331  
[priyanka.rai\(at\)binarysemantics.com](mailto:priyanka.rai(at)binarysemantics.com)

#### Japan

Eiji Yoshikawa +81 3 6751 0090  
[scala\(at\)s3.dion.ne.jp](mailto:scala(at)s3.dion.ne.jp)

#### South Korea

Jung Won Suh +82 2 78 58 222  
[sinsegi\(at\)sinsegi-media.info](mailto:sinsegi(at)sinsegi-media.info)

#### Taiwan

Leon Chen +886 2 256 81 786-10  
[leon\(at\)jkmedia.com.tw](mailto:leon(at)jkmedia.com.tw)

#### UK, Ireland, Benelux, Scandinavia

Zena Coupé +44 1923 85 25 37  
[zena\(at\)expomedia.biz](mailto:zena(at)expomedia.biz)

#### US East

Karen C Smith-Kernc +1 717 397 7100  
[KarenKCS\(at\)aol.com](mailto:KarenKCS(at)aol.com)

#### US West & Canada

Alan A. Kernc +1 717 397 7100  
[AlanKCS\(at\)aol.com](mailto:AlanKCS(at)aol.com)

## Copyrights - Luger Research e.U.

The editors make every reasonable effort to verify the information published, but Luger Research e.U. assumes no responsibility for the validity of any manufacturers, non profit organizations or individuals claims or statements.

Luger Research e.U. does not assume and hereby disclaims any liability to any person for any loss or damage caused by errors or omissions in the material contained herein, regardless of whether such errors result from negligence, accident or any other cause whatsoever. You may not copy, reproduce, republish, download, post, broadcast, transmit, make available to the public, or otherwise use LED professional Review (LpR) content without prior written consent from Luger Research e.U. - Institute for Innovation & Technology, Austria. ■



# CONTRIBUTE

to the LED professional Review

## EDITORIAL CALENDAR 2019

ISSUE N°	IN THE SPOTLIGHT*/**	DUE	ARTICLE DUE	ONLINE PUB.	PRINT PUB.
<b>71</b> Jan./Feb.	<b>TECHNOLOGIES FOR HEALTH &amp; WELL-BEING</b> Efficient lighting has become a prerequisite. Ongoing discussions question whether efficient lighting is also healthy lighting and if it supports well-being. Findings, technologies, designs and applications supporting health and well-being are the focus of this issue.	Oct. 15, 2018	<b>Oct. 22, 2018</b>	Jan. 15, 2019	Feb. 01, 2019
<b>72</b> Mar./Apr.	<b>FUTURE PROOF SYSTEMS &amp; SOLUTIONS</b> Most buildings are constructed to last at least four decades. Owners and operators are only willing to invest in long lasting future proof solutions for the infrastructure. The topic of this issue is the question of if and what future-proof solutions and technologies are available.	Dec. 17, 2018	<b>Jan. 04, 2019</b>	Mar. 15, 2019	April 01, 2019
<b>73</b> May./June	<b>DISRUPTIVE TECHNOLOGIES &amp; APPROACHES</b> A good part of the lighting industry suffers from high production costs – especially in Europe and the US. New concepts, designs, materials and manufacturing methods may be advantageous. This issue reveals the most ingenious approaches.	Feb. 25, 2019	<b>Mar. 04, 2019</b>	May 15, 2019	June 03, 2019
<b>74</b> July/Aug.	<b>TECHNOLOGIES FOR SPECIFIC TASKS &amp; APPLICATIONS</b> Light is not only used for illuminating rooms and open spaces. The applications of LEDs are manifold. This issue acknowledges the importance of LED light sources in automotive, horticultural, medicinal, cosmetic, and environmental applications, to name just a few.	April 24, 2019	<b>May 06, 2019</b>	July 16, 2019	Aug. 01, 2019
<b>75</b> Sept./Oct.	<b>ENVIRONMENTAL FRIENDLY DESIGN &amp; ENGINEERING</b> The EU Commission supports the move towards a more circular economy. Additionally, research demonstrates that artificial light may negatively affect the environment. Technologies, designs and solutions that recognize these two aspects are addressed in this issue.	June 26, 2019	<b>July 05, 2019</b>	Sept. 02, 2019	Sept. 24, 2019
<b>76</b> Nov./Dec.	<b>TECHNOLOGIES FOR VISUAL PERFORMANCE &amp; COGNITION</b> Some research results suggest that the spectral properties of a light source have great influence on visual performance, cognition and arousal. But it is more than just the spectrum that counts. This issue presents supporting concepts, technologies and solutions.	Aug 06, 2019	<b>Aug 26, 2019</b>	Nov. 15, 2019	Dec. 02, 2019

# HortiCoolture. LED it grow!



#LEDITGROW

*WE speed up  
the future*

PCIM Europe Hall 7 Booth 229

## Horticulture LED Lighting

New horticultural products from the high power ceramic series. Specially chosen wavelengths (450 nm, 660 nm and 730 nm) increase photosynthesis, optimizing plant development and growth. With outstanding PPF-value, small size and low power consumption, the WL-SMDC is the future choice for horticultural lighting. Available ex stock. Samples free of charge.

For further information please visit:  
[www.we-online.com/leditgrow](http://www.we-online.com/leditgrow)

For a short introduction of Horticulture LEDs read our Application Note:  
[www.we-online.com/AN-Horti](http://www.we-online.com/AN-Horti)

- High efficacy
- Individually adjustable color spectrum for each plant
- Full color spectrum available incl. white, UV and IR-LEDs
- Low thermal resistance
- Electrically neutral thermal path
- One footprint for all colors

