



# Weathergard® Series

## Severe Environment LED Exits

### Description

Rugged self-diagnostic LED exit signs for use in damp/wet environments or areas of potential abuse. Exits feature corrosion-resistant polycarbonate enclosures and cast aluminum housings.

### Features

#### All Models

- Rugged wraparound polycarbonate enclosure
- Sturdy die cast aluminum exit frame
- Corrosion resistant, gasketed construction with vandal resistant hardware
- Long life, high intensity LED lamps
- Red or green exit letters
- Wall, ceiling and end mount models
- Universal directional chevrons provided by means of knockouts
- Choice of white, black, gray or brushed finish
- UL Damp and Wet Location listed

#### Emergency Models

- Self-diagnostic operation standard
- Universal 120/277VAC field selectable input
- Solid-state charging and switching circuits
- Two-stage, temperature compensated charger
- Long life nickel cadmium battery with quick connect plug assembly
- 120 minutes of emergency operation
- Automatic low voltage battery disconnect, brownout, surge and AC lockout protection
- Manual test and infrared interface activated test switch capability
- LED AC indicator light
- Optional audible self-diagnostic alert alarm
- -40°F to 113°F (-40°C to 45°C) operating temperature
- Meets NFPA Life Safety Code 101, NEC, BOCA, IBC, OSHA, State and local codes
- ADA compliant
- UL924 listed

### Specifier Reference

Project: \_\_\_\_\_  
 Fixture Type: \_\_\_\_\_  
 Model No.: \_\_\_\_\_  
 Comments: \_\_\_\_\_



**Self-Diagnostic  
Operation  
Standard!**



### Ordering Guide

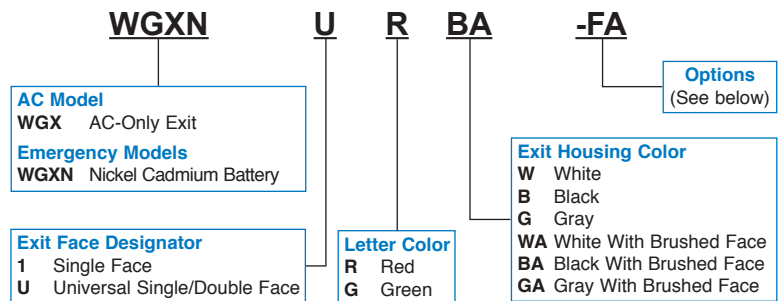

NOTE: All product specifications shown are subject to change without notice.

### Options<sup>(1)(2)</sup>

Add Suffix	Description
-TC11	Two-Circuit Input (120VAC)
-TC12	Two-Circuit Input (277VAC)
-EX	Special Input Transformer (consult factory) <sup>(1)</sup>
-FL	Visual Intermittent Alarm
-BF	Audio-Visual Intermittent Alarm (emergency models only)
-FA	Fire Alarm Panel Interface
-TA	Audible Self-Diagnostic Alert Alarm (emergency models only)
-PM	Pendant Mount (order Accessory Pendant Kit separately)
-SW	Special Wording (consult factory)

(1) Other options available. Consult factory.

(2) Some options may impact product UL listing. Consult factory.

### Accessories

Order Model	Description
IRT	Infrared Remote Testing Device
TP	Tamper Proof Tool
SK12W	12" Pendant Stem Kit (white) <sup>(3)</sup>
SK12B	12" Pendant Stem Kit (black) <sup>(3)</sup>
WG4	Wire Guard - Wall Mount
WG10	Wire Guard - Ceiling/End Mount

(3) Unit must be ordered with the -PM option for compatibility with the pendant stem kit. Other lengths available. Consult factory.

## Construction

**Enclosure:** Clear polycarbonate wraparound cover with full neoprene perimeter gasket.

**Frame:** Cast aluminum housing finished in baked-on powder paint providing scratch and corrosion resistance. White, black, gray and brushed finishes available.

**Canopy:** Cast aluminum canopy finished to match exit housing. Supplied with neoprene gaskets for sealing to housing and mounting surfaces.

## Exit Face

**Letter Size:** 6" letters with 3/4" stroke

**Directional Indicators:** Removable chevron arrows sized to meet UL visibility requirements.

## Illumination

**Illumination Source:** Exit face illumination in both AC and emergency modes is provided by a special high intensity indirect red or green LED panel (depending on model). Letter brightness and illumination uniformity exceed UL requirements in all models. Average illumination level exceeds 25ft

## Installation

**Mounting:** All models are designed for mounting to 3 1/2" or 4" octagonal electrical boxes. Surface wiring provisions include two 1/2" conduit entries in the unit housing. Ceiling and end mount applications are provided for by means of mounting canopies supplied with all models. Neoprene gaskets are provided for sealing to mounting surfaces in all applications. Pendant mounting is also possible using available accessory pendant kits. See Options and Accessory sections on front of sheet for ordering details.

## Power Consumption

	Red Letters		Green Letters	
	120V	277V	120V	277V
AC-Only LED Models	3.8W	3.8W	4.0W	4.0W
Power Factor	.96	.91	.95	.90
Emergency LED Models	4.7W	4.8W	4.7W	4.7W
Power Factor	.95	.97	.95	.99

## Code Information

All models are UL Damp and Wet Location listed and meet NFPA 101 Life Safety Code, NEC, BOCA, IBC, OSHA, state and local codes. Emergency models are UL924 listed.

## Charger and Electronics

**Charger Type:** Fully automatic, two rate, temperature compensating, constant current type charger.

**Utility Input:** 120/277VAC, 60 Hz.

**Temperature Range:** -40°F to 113°F (-40°C to 45°C)

**Recharge Duty Cycle:** 24 hours

**Load Transfer:** Solid state transfer circuit

**Controls:** Manual momentary test switch, infrared activated test switch and LED AC-On indicator light

**Safety Circuitry:**

**AC Lockout:** Prevents battery discharge prior to AC power-up

**Low Voltage Battery Disconnect:** Protects the battery from deep discharge during prolonged power failures.

**Brownout Protection:** Switches the unit to emergency operation when AC voltage sags below 80% of nominal.

**AC Surge Protection:** Prevents damage to unit from utility surges and voltage spikes

**Reverse Utility and Battery Connection Protection**

## Dimensions

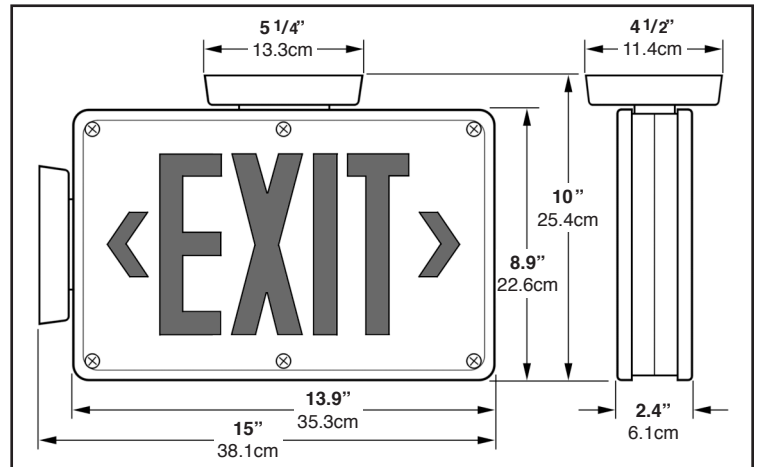

## Visual Self-Diagnostic Fault Indicators

The Weathergard self-diagnostic circuitry is capable of providing a visual fault indication of the following conditions:

Fault Condition	Indicator
Battery Disconnect/Failure	Red LED 1X Flash Rate
LED Lamp Failure	Red LED 2X Flash Rate
Battery Charger Failure	Red LED 3X Flash Rate
Transfer Circuit Failure	Red LED 4X Flash Rate
AC Line Under-Voltage	Red and Green LEDs Slow Alternate Flash
AC Line Over Voltage	Red and Green LEDs Fast Alternate Flash

## Self-Diagnostic Emergency Operation

Standard self-diagnostic circuitry continuously checks LED array, charger, battery and transformer operation. A bi-color LED interface provides unit status and operational readiness information. Coded LED flash signals identify fault type if detected. Automatic diagnostic/discharge cycling includes a one-minute monthly test and a 30-minute test every sixth and twelfth months. Upon failure of the normal utility power or a brownout condition where voltage sags below 80% of nominal, a solid-state transfer switch automatically switches the unit to emergency mode providing uninterrupted operation. Emergency illumination of the LED array will be supplied for a minimum of 120 minutes. During emergency operation, the exit battery is protected from severe discharge damage by an automatic low voltage disconnect circuit that discontinues unit operation when battery voltage reaches 87.5% of nominal. When normal utility power is restored, the battery is automatically disconnected from the load and a recharging cycle begins.

## Infrared Remote Tester Accessory

Weathergard emergency exit signs can be tested using the unit's integral manual test switch or with activation of a built in infrared sensor using the IRT infrared remote testing device (See "Accessories" on front of sheet). The hand-held IRT interface allows a user to activate a 1-, 30-, or 90-minute discharge test with the touch of a button from up to 40 feet from the exit location. The IRT device also provides the ability to silence the audible signal on Weathergard models equipped with the -TA self-diagnostic alert alarm option.



## Battery

**Emergency Models:** Sealed Nickel Cadmium longest life maintenance free battery.

## Warranty

**Unit:** 3 years full coverage against defects in materials and workmanship from date of shipment

**Battery:** 3 years full warranty plus an additional 7 years of pro-rata coverage